

**Declaration of Conformity**



**Standard Engineering Limited**

10 Garrard Way  
Telford Way South  
Kettering, Northamptonshire  
NN16 8TD England

Fax: +44 (0) 1536 410755

Tel: +44 (0) 1536 517070

www.standardgroup.co.uk

In respect of the following directive:

European machinery Directive (89/392 EEC as amended by 91/368/44EEC).

Company Standard Engineering Ltd  
10 Garrard Way  
Telford Way Industrial Estate South  
Kettering  
Northamptonshire  
NN16 8TD

Machine Insole Stitching Machine

Type Geneva

Model 849

Serial No.

Conforming to standards :

EN292: Part 1 & 2  
EN294: 1992  
EN349: 1992  
EN894-2: 1997  
EN953: 1997  
EN954-1: 1996  
ENV1070: 1993  
EN60204-1: 1992



This is to declare that the above machine conforms with the relevant Essential Health and Safety Requirements of the European Machinery Directive (89/392 EEC as amended by 91/368 EEC and 93/44 EEC).

M.J. Greasley  
Technical Engineer  
Standard Engineering Ltd.

Issued 13.3.03

## The GENEVA Lockstitch Sole Sewing Machine

### Installation

Position the GENEVA on a firm floor area and ensure that it cannot rock by packing the corners of the base if necessary. The GENEVA should be located in a position which allows freedom of access without obstruction. This is both for safety and for maximum ease of use.

### Electrical connections

#### (a) SINGLE PHASE MACHINE

This will have a single cable which, in the UK, should be connected to a 240V supply safeguarded by a fuse rated at 13 amps. The cable is colour coded:-

Brown	Live
Blue	Neutral
Yellow/Green	Earth

#### (b) THREE PHASE MACHINE

This will have two cables attached. The single phase one (colour coded as above) should be connected to a 5 amp fused supply.

The three phase cable will be colour coded:-

Phase 1	Black
Phase 2	Brown
Phase 3	Blue
Earth	Earth

and should be connected to a 3 amp per phase fused supply. The supply will be correctly connected if the handwheel rotates clockwise when viewed from the right hand side of the machine.

### The controls

- (a) On/Off push buttons control the main motor. This is a clutch motor so can be switched on without stitching taking place. However, it is very quiet, so please check that it is switched off when the machine is not in use or when carrying out adjustments such as needle or bobbin changes.
- (b) Red rocker switch directly operates the bobbin winder motor.
- (c) Left hand foot treadle lifts the presser foot to enable the shoe to be positioned or removed.
- (d) Right hand foot treadle starts the stitching mechanism.

### Machine Speed

The GENEVA is set to run at 100 stitches per minute when supplied and it is recommended that the operator should become fully conversant before the drive is adjusted to the higher speed of 160 stitches per minute if required.

This operation is carried out by slackening the belt tensioner on the motor, removing the motor pulley and replacing it with the larger one provided in the kit. Re-align the motor pulley to ensure that the belt is running vertical and re-tension the belt taking care not to overtighten.

### Preparation for stitching

1. Fill the lubricating pot MP 1310 with a solution to lubricate the thread, i.e. 25% soluble oil mixed with 75% water. The thread feeding from the machine base must always be wet when stitching when using linen thread. Lubrication is optional for polyester braided threads.

Preparation for stitching (cont'd)

2. Refer to Plate 1 to ensure that the bottom thread has been correctly fed through the various rollers up into the horn and note the following points:-
  - (a) The cop of thread must be correctly positioned on the cop holder 'F'. Ensure that the leading thread is not trapped between the cop and cop holder dish section.
  - (b) The thread must always pass through the rear hole and then the hole in the shaft between the two spring loaded discs of the secondary thread tensioner 'D'. (NOT REQUIRED WITH HORIZONTAL TYPE COP HOLDERS INTRODUCED IN DECEMBER 1989).
  - (c) The thread must always pass through the hole in the shaft between the two spring loaded discs of the primary tensioner 'C'.

To obtain access to the centre hole in both the primary and secondary tensioners, it is advisable to pull the front disc forward against the spring until a gap appears. With the thread located in the threader provided, lead it through the hole in the direction shown. Release the disc to close the gap.

The tension on the secondary disc is preset and should not require adjustment for normal types of thread.

- (d) When the thread is passed through the various thread rolls 'E', it is important that the thread passes through the entry and exit shown without touching the outer casing.
- (e) The thread must be placed between the two lock discs 'B' when the mechanism opens the two discs allowing access. If the discs are closed, turn machine by hand until they open.

DO NOT UNLOCK THESE DISCS TO OPEN THEM

### Preparation for stitching (cont'd)

- (f) The thread must pass through the small hole in the whirl 'A' in the direction shown.
3. Check that the bobbin has been wound and that it has been correctly inserted into the bobbin case MP1220 as shown in Plate 5A. The bobbin thread should normally be waxed.
4. IMPORTANT: ensure that the small protrusion on the bobbin case MP 1220 is correctly engaged in the slot in the retaining plunger MP 1225 (Plate 5C).
5. It is useful to turn the GENEVA over by hand a few times using a piece of waste leather to see how the stitch is formed and to check that the machine is working freely.

### Stitching

Pull the bottom thread up from the base until it is wet, then secure it under spring clips MP 213. Position the bow of the horn to the left and rotate the handwheel until the presser foot is positioned close to the needle. The foot can then be raised using the LH treadle to allow the work to be positioned on the horn. Clamping of the work is then achieved by releasing the treadle.

Stitching can then commence by operating the RH foot treadle carefully using both hands to guide the work as required. The stitch length can be altered by adjusting the knob MP 1249 on the right hand side of the machine head.

To stop stitching, release the foot treadle and rotate the machine by hand until the needle is roughly in its highest position. The work may then be removed from the GENEVA by pressing the LH foot treadle to raise the presser foot.

### To load new bobbin into GENEVA

- (a) Pass the free end of the thread through the hole in the side of the bobbin case MP 1220 (Plate 5A).
- (b) Press the bobbin into the bobbin case. It is advisable to place a few drops of machine oil in the housing before pressing in the bobbin.
- (c) Feed the thread into the slot down the side of the bobbin case and check that it can be freely pulled through (Plate 5A).
- (d) There may occasionally be a build-up of wax deposit between the shuttle and the bobbin case. This should be removed using a solvent and the bobbin case lightly oiled so that it rotates freely in the shuttle.
- (e) Pull back the spring loaded plunger and position the shuttle case so that the small protrusion fully locates in the slot of the plunger, as shown on Plate 5B and Plate 5C.

### Threading the GENEVA

The thread path through the GENEVA is shown on Plate 1 and 1A. Access is obtained by removing the base front door.

### Needle setting

When a new needle is fitted, the shank end must locate up to the stop pin MP 1235 situated inside the needle bar MP 1202.

The hook of the needle must be directed to the right when viewed from the front of the GENEVA. Ensure that the clamp screw is secure. When the needle is in its lowest position, the top of the needle barb must be just below the hole in the whirl MP 1238.

### Setting of whirl and pinion

Rotate the handwheel until the shuttle point is in line with the needle, Plate 3A. Rotate the horn so that the horn tip is pointing towards the GENEVA column. Remove the horn cap MP 1372. The hole in the whirl should be positioned at 3 o'clock as shown in Plate 3B. It is important that if a new whirl or pinion is fitted, then the engagement of the teeth must be correct - this is also shown on Plate 3B. Adjustment is made by removing the horn tip MP 209 and pinion MP 1237 and rotating the small screw situated at the end of MP 205. Only small adjustments to this screw should be required.

### Bobbin winding

The high speed bobbin winder is situated in the belt guard immediately below the handwheel.

A cop of pre-waxed thread is positioned on the hand spool holder and the thread path up to the tensioner as is shown on Plate 2 and 2A.

A bobbin can be loaded by simply pressing it onto the shaft with the two small holes towards the belt guard. One of these holes should be engaged with the driving pin. The bobbin is retained on the shaft by spring loaded balls.

The thread can then be led from the tensioner at the front right hand side of the GENEVA back to the bobbin and from left to right through the small hole in the outer bobbin flange. The end of this thread should be held about 50mm from the bobbin. The winder motor is then started by operating the red rocker switch on the front of the base; the thread end can be released almost at once.

It will be seen that the bobbin winds very quickly and the distance between the tensioner and bobbin winder is sufficient to enable the thread to lay very evenly in the bobbin. This ensures that the bobbin is loaded to capacity with thread and it helps give an even tension when stitching.

### Bobbin winding (cont'd)

When the bobbin has been sufficiently wound, the red rocker switch is turned off to stop the motor.

The fixed end thread can then be parted off flush with the flange of the newly wound bobbin.

### Maintenance

At all times, the GENEVA should be kept clean and the path the threads take must be free of dirt and sharp edges. In addition, the following procedure will extend the life of your stitcher:

- DAILY
- lightly oil bobbin case where it fits into the shuttle
  - rotate machine by hand and lightly oil shuttle bearing faces
  - check level of thread lubricant
- WEEKLY
- oil top of needle bar and presser foot bar where they protrude through the top of the head
  - lightly oil bobbin winder shaft bearing
  - lightly oil the horn tip and the three oiling points on the horn
- MONTHLY
- remove the head front cover by undoing the two securing screws and oil all moving parts
  - remove base front door and oil all accessible moving parts.

### Recommended thread and needle signs

- |                        |                                |
|------------------------|--------------------------------|
| Needle:-               | No. 6 Blake hook               |
| Bottom (horn) thread:- | Power polyester braided thread |
| Top (bobbin) thread:-  | Power polyester braided thread |



### Recommended thread and needle signs (cont'd)

The above specifications are for linen thread and it is recommended that a good quality product is used. Some lower quality threads can cause stitching problems.

The GENEVA is also suitable for use with braided threads which are commonly from man-made fibres.

### Machine setting and fault finding

If a stitching problem is encountered, a check should be made to ensure that the settings are correct to form a stitch. To do this, the machine should first be threaded up, Plate 1.

Take the thread coming through the whirl (check that it is threaded through the small hole in the whirl) and loop it lightly with the thumb against the horn tip while holding the horn bow to the left.

Turn the handwheel, by hand, in the direction indicated until the needle passes down through the whirl which will rotate placing the thread on the needle barb, continue turning the handwheel and the needle will lift from the horn pulling a loop of thread with it.

When the tip of the needle is level with the shuttle, the shuttle will start to move from left to right and the adjustable shuttle point will split the loop of thread immediately below the needle. The needle will continue to rise and the shuttle will continue to rotate from left to right. When the needle reverses and starts its downward movement, the loop of thread is pulled clear of the barb and carried round the back of the shuttle.

The shuttle then stops and the thread is pulled down into the work completing the locked stitch. If this sequence does not occur, some checks can easily be made.

Machine setting and fault finding (cont'd)

1. If the needle does not pick up a loop of thread, check the whirl settings and the needle settings. The needle could be going down too far or not far enough or the barb could be pointing in the wrong direction.
  
2. If the adjustable shuttle point does not split the loop of thread, check that
  - (a) the adjustable shuttle point passes close to the tip of the needle as the needle is rising (Plate 4A). If this is not the case, it is possible that the machine timing has been disturbed and a service engineer should be called in.
  
  - (b) the shuttle point passes immediately under the needle (Plate 4B). If it is out of line, adjustment can be made by slackening the two small socket set screws and moving the adjustable point so that the tip passes close to and directly under the needle.

Stitching under power can now take place. The 'lock' produced by the horn thread and the bobbin thread should be pulled into the material. The position of the lock can be adjusted by altering the tension of the bottom thread by turning the knob on the front of the GENEVA base. Clockwise will pull the lock in more, anti-clockwise will allow it to lay nearer the visible side of the work.

# DIAGRAM FOR VERTICAL TYPE COP HOLDERS

PLATE 1

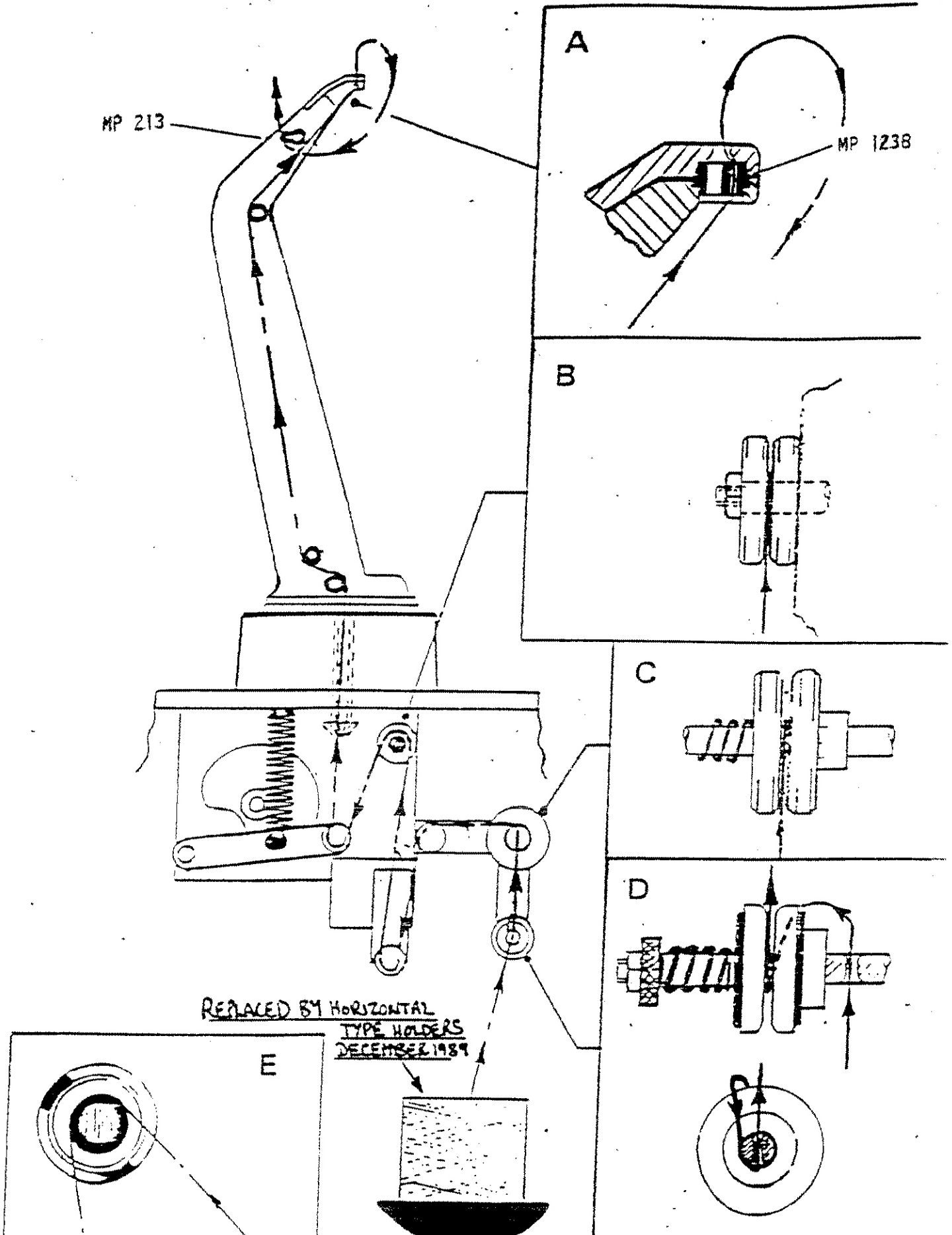

# DIAGRAM FOR VERTICAL TYPE COP HOLDERS

PLATE I

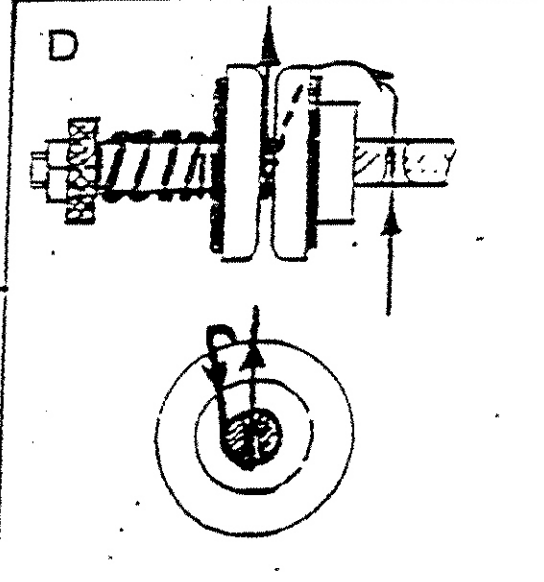
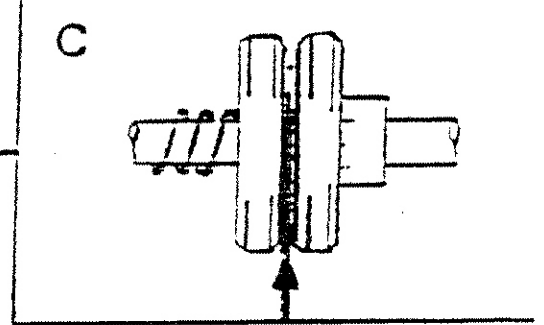
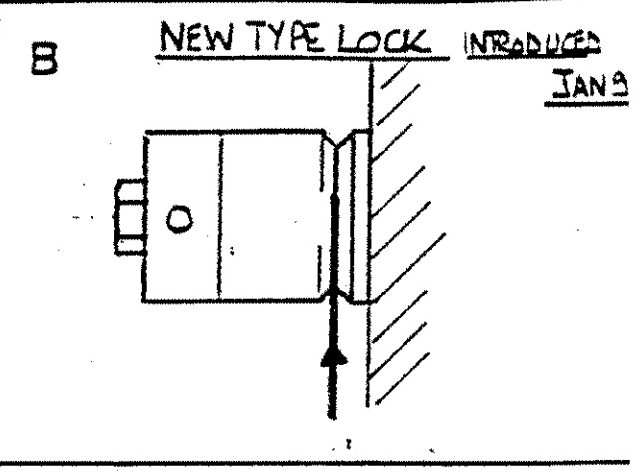
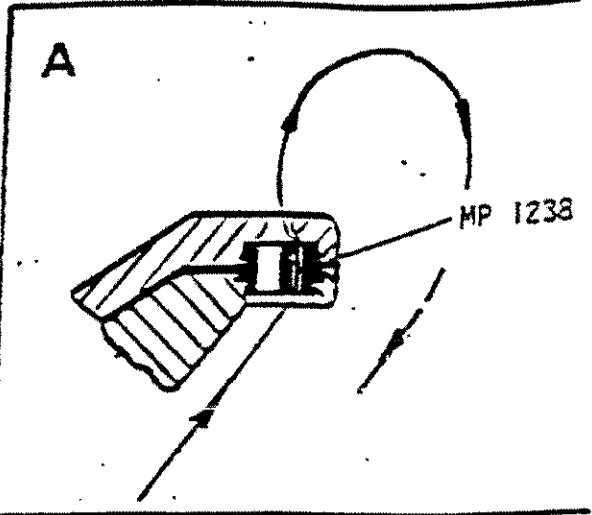
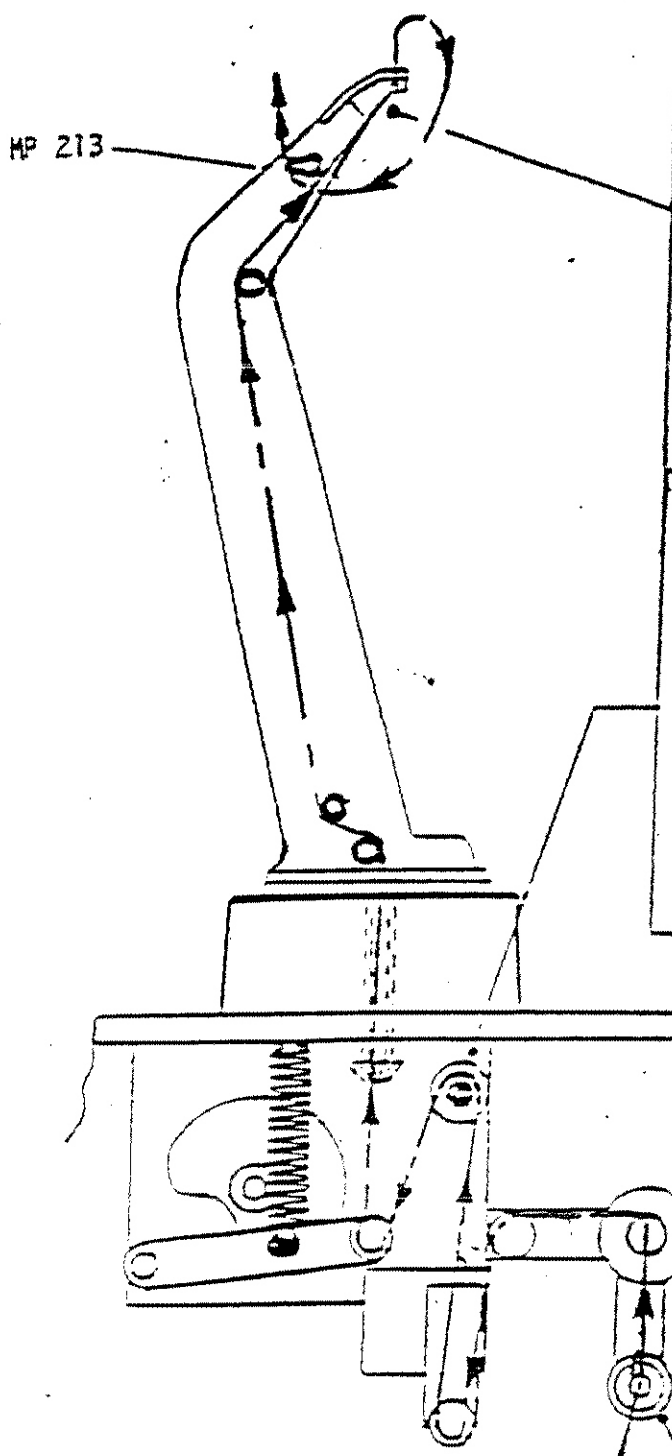

REPLACED BY HORIZONTAL  
TYPE HOLDERS  
DECEMBER 1989

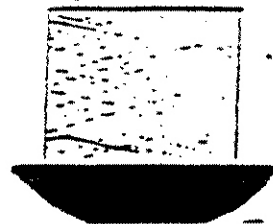
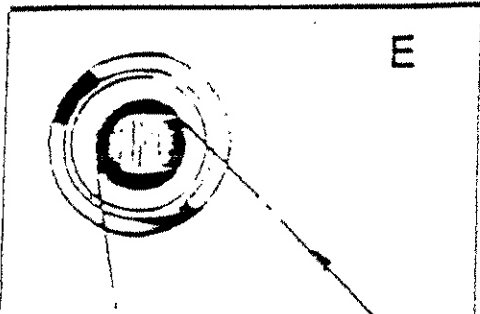

PLATE 1A

THREADING DIAGRAM FOR HORIZONTAL  
TYPE COP HOLDER

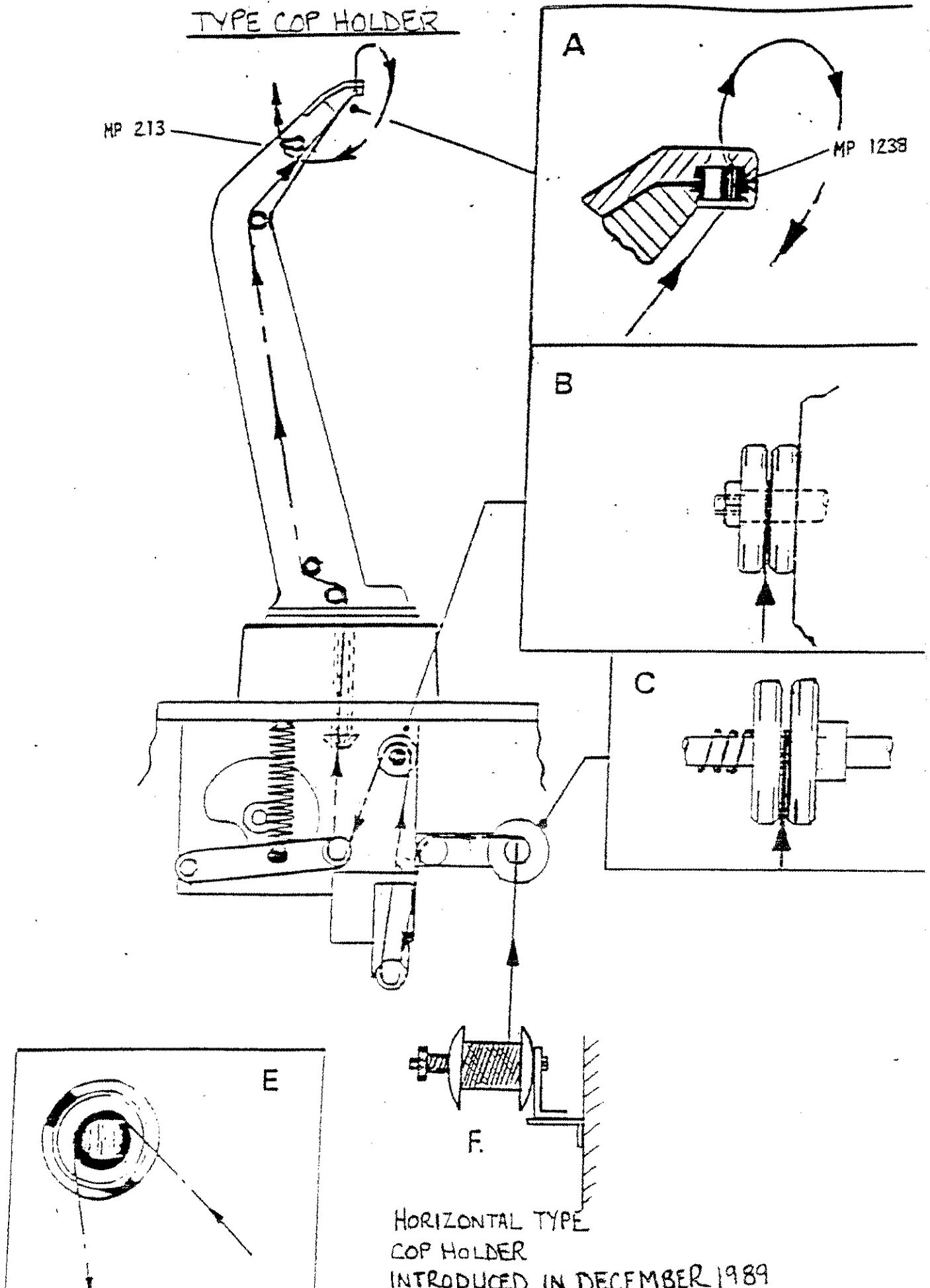

PLATE 2

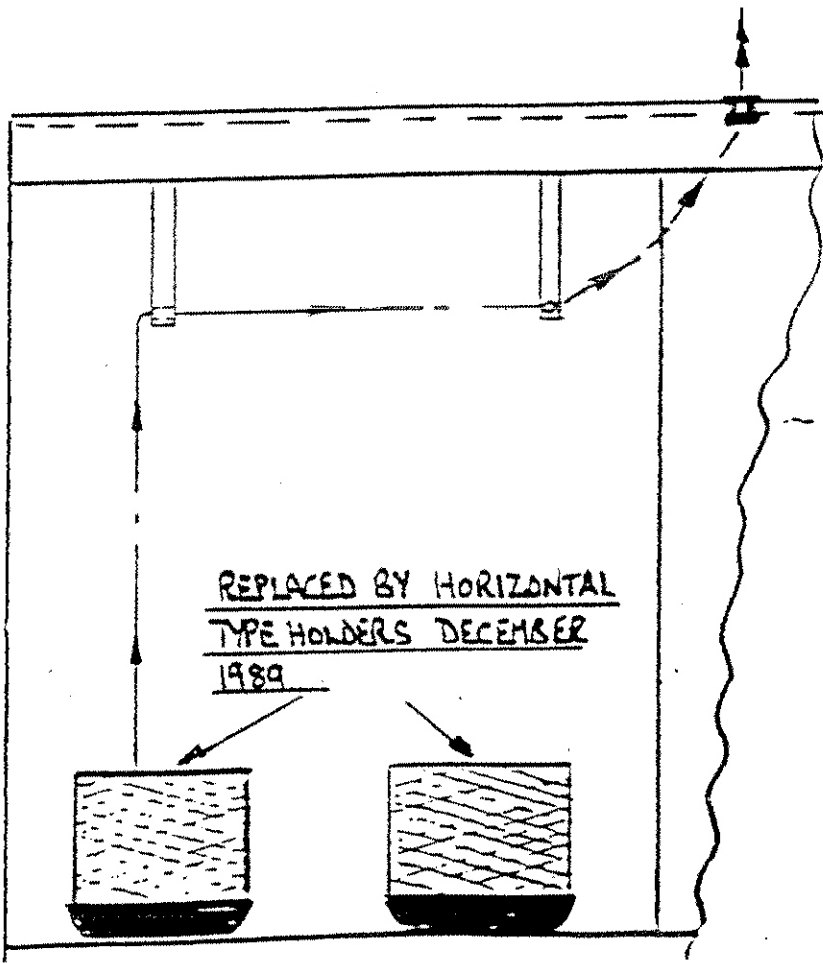
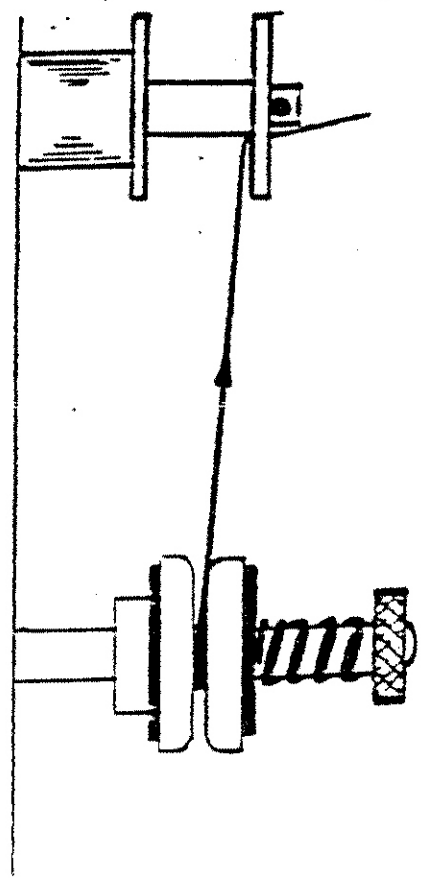
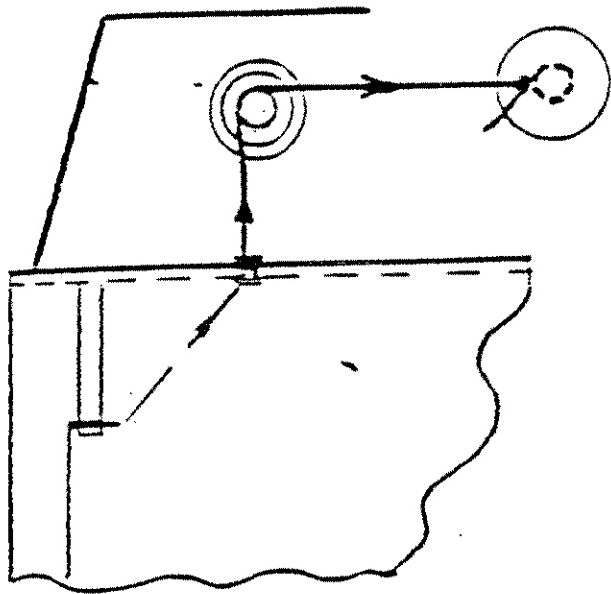
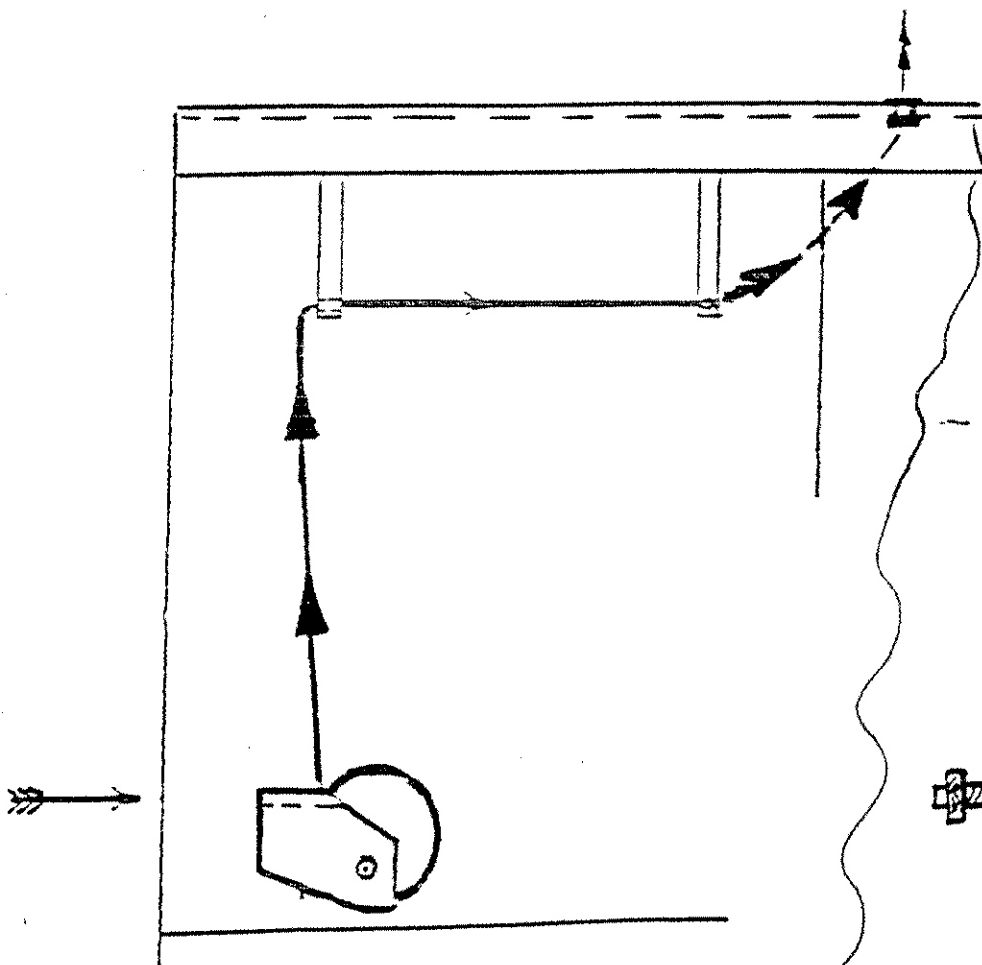
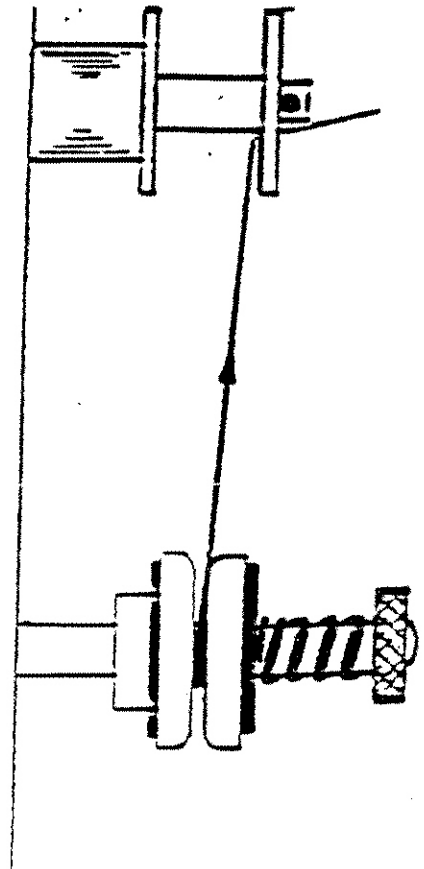
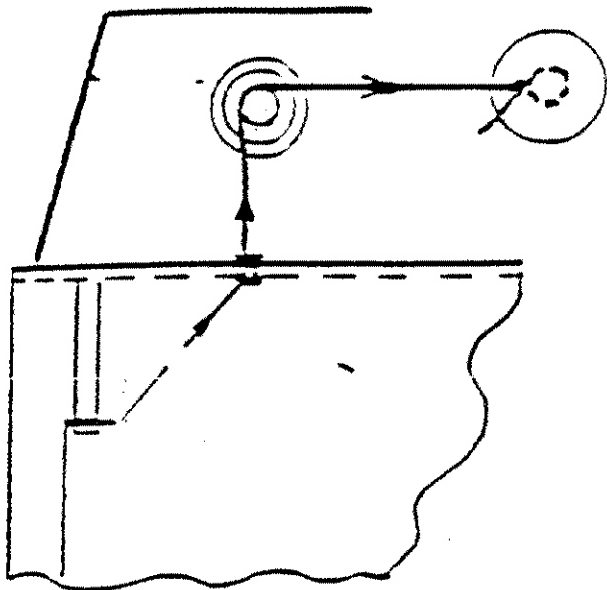

PLATE 2A



INTRODUCED  
DECEMBER 1989

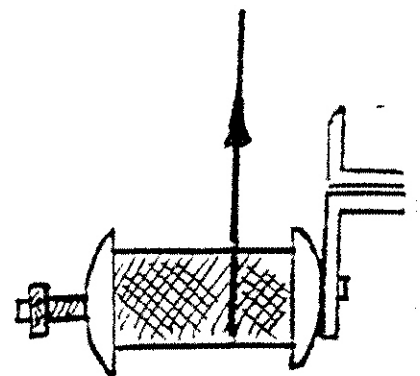

PLATE 3A

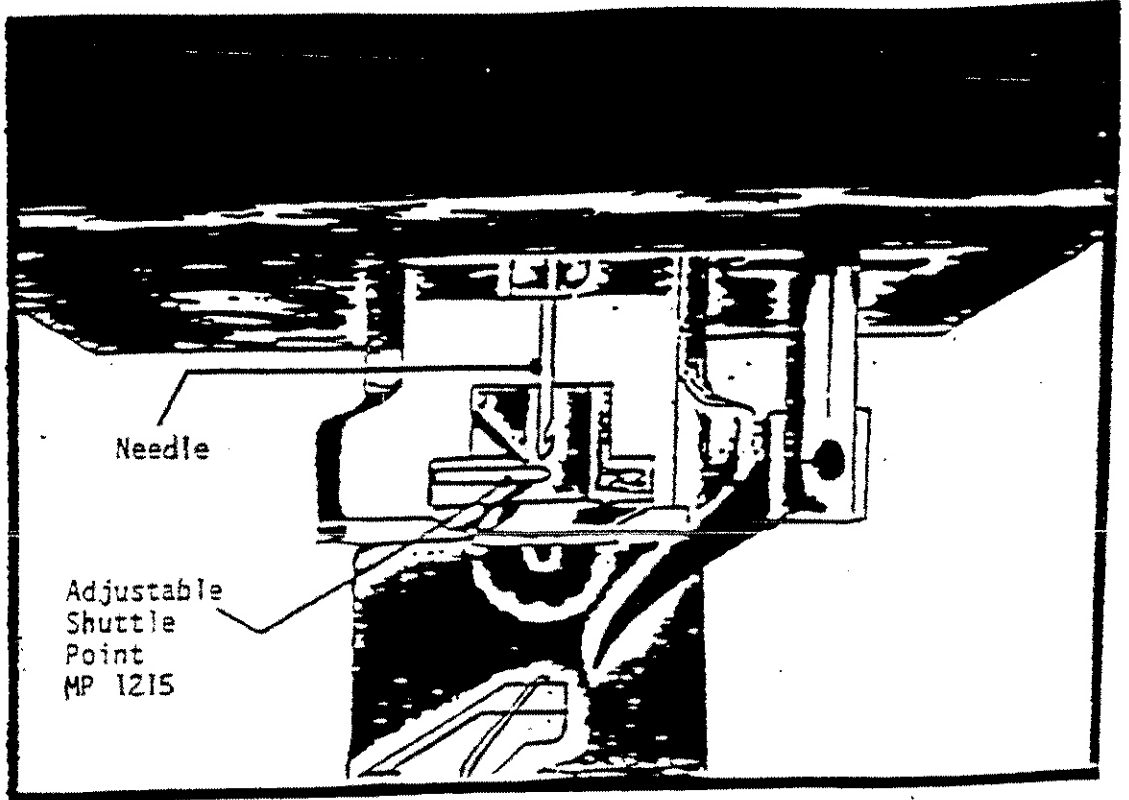

PLATE 3B

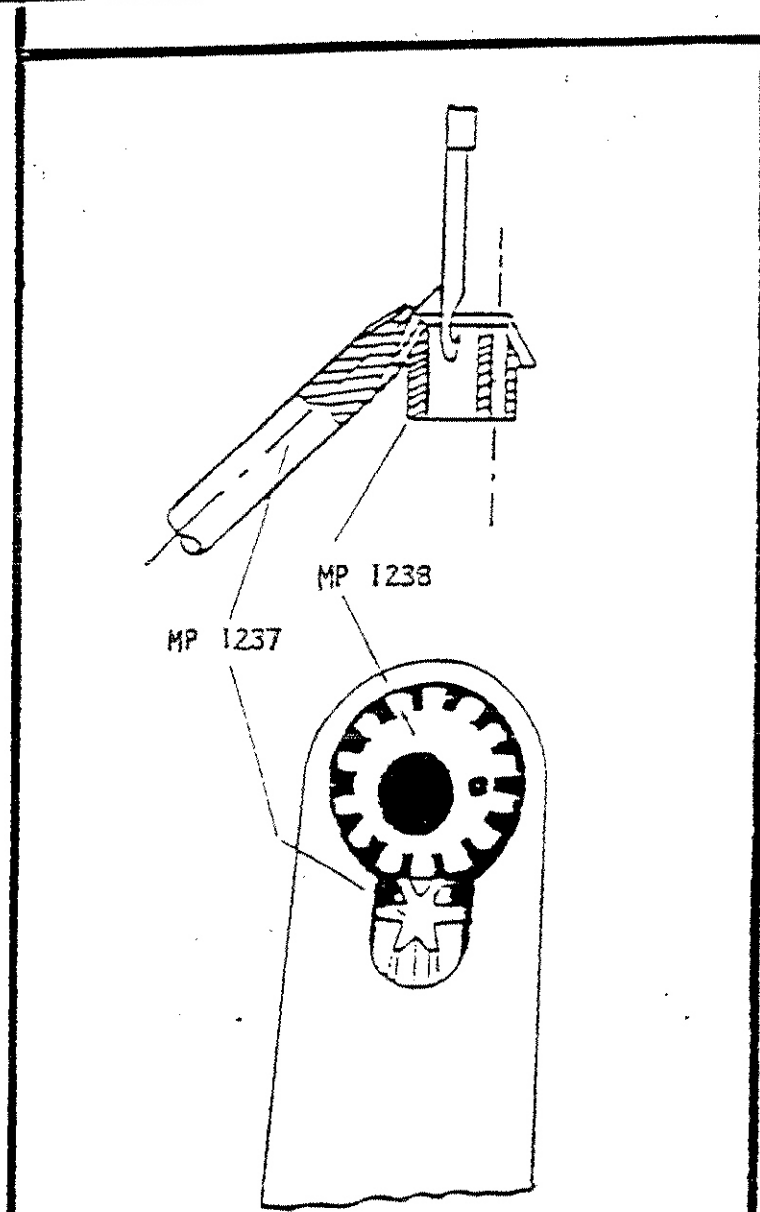



PLATE 4A

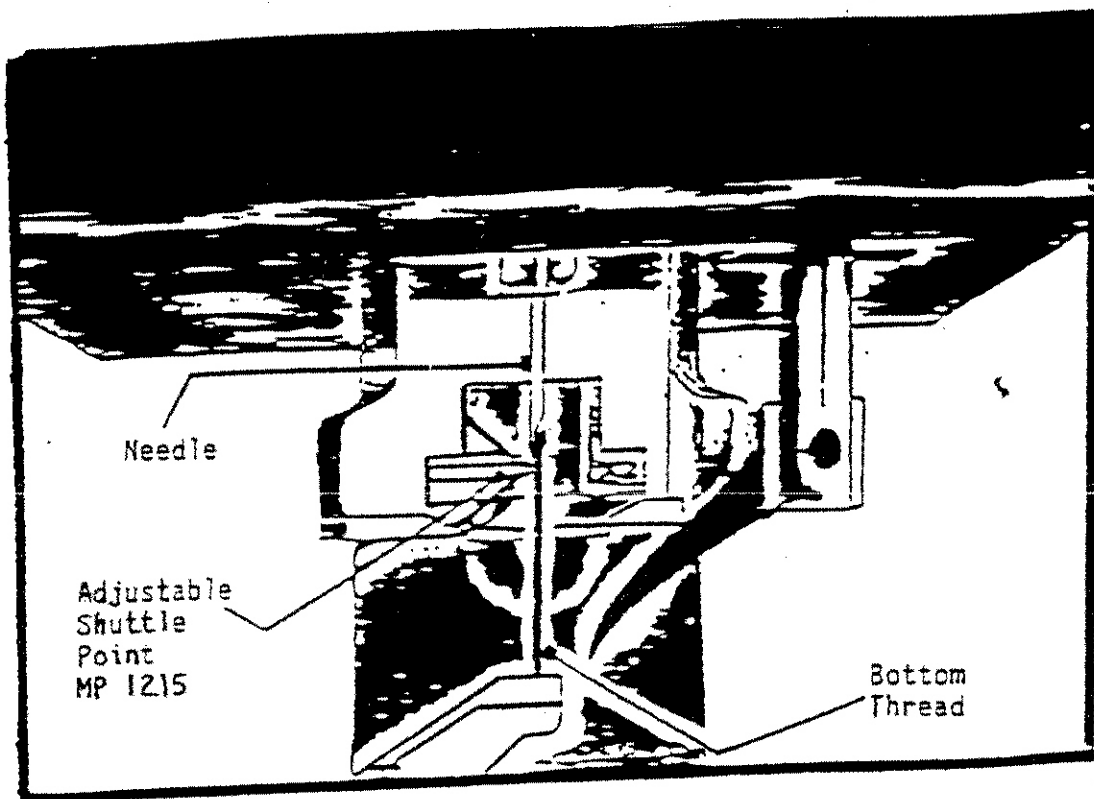
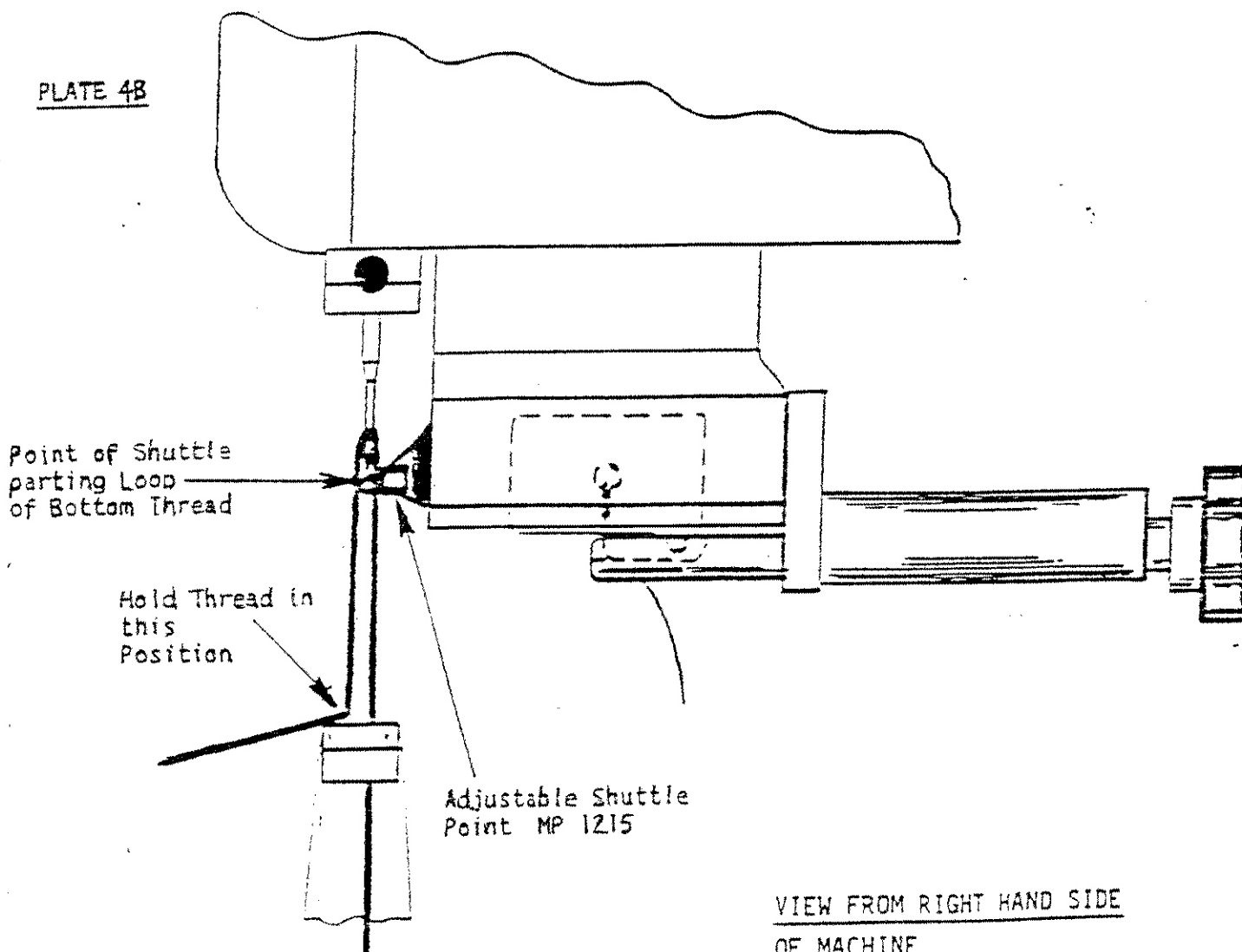

PLATE 4B



VIEW FROM RIGHT HAND SIDE OF MACHINE

PLATE 5A

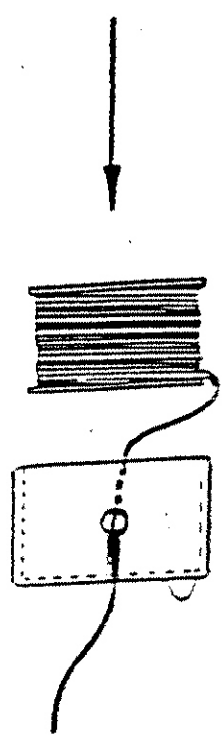

PLATE 5B

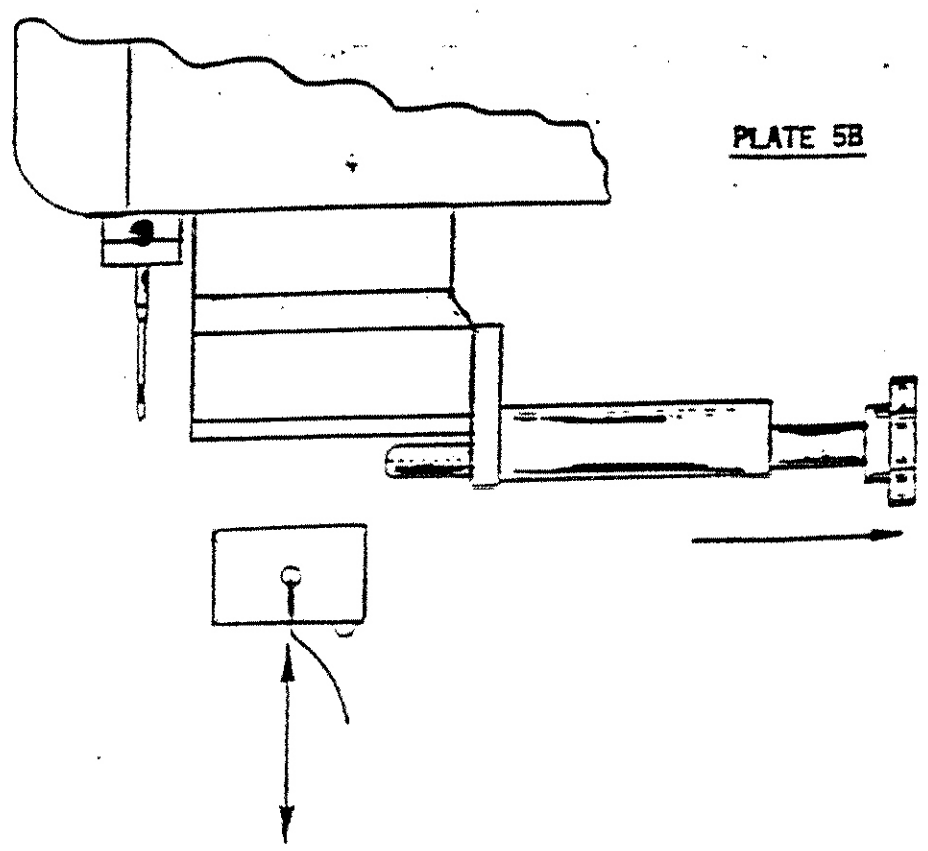
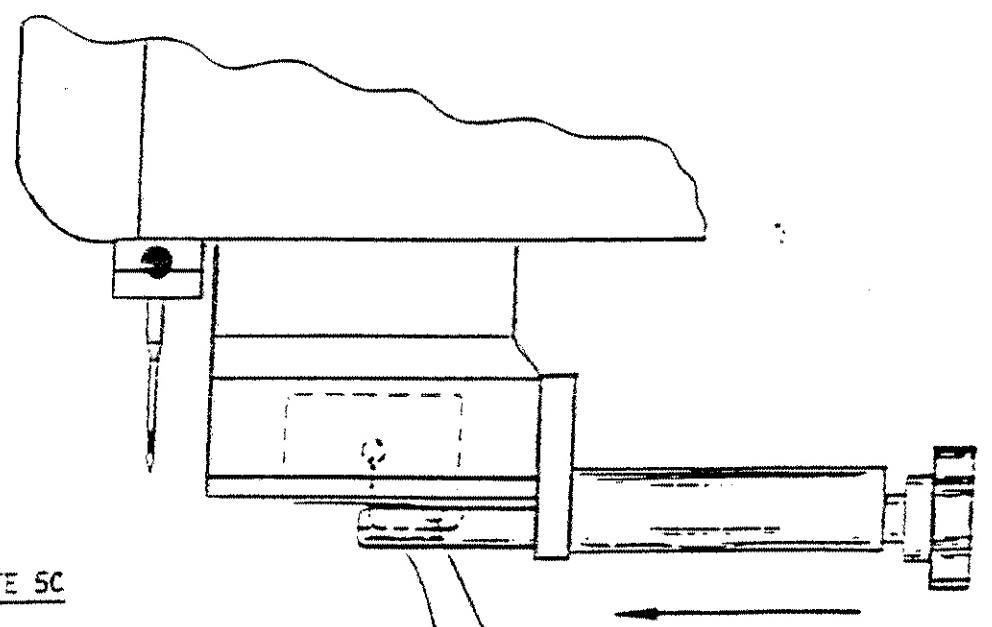

PLATE 5C



IMPORTANT

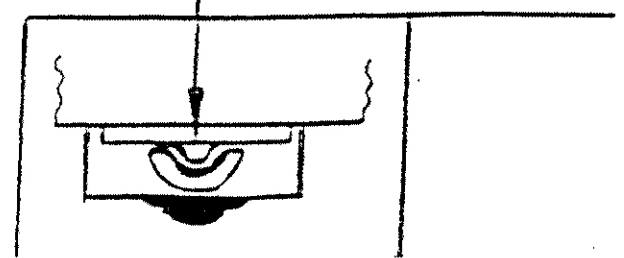

PLATE 1  
HORN BASE ASSEMBLY

<u>PART NUMBER</u>	<u>DESCRIPTION</u>
MP 1008	CENTRE SHAFT
MP 1009	HORN DRIVE SHAFT BOTTOM GEAR
MP 202	WHIRL GEAR DRIVE (UPPER)
MP 1002	HORN TURNTABLE
MP 1001	HORN BEARING HOUSING
MP 1298	LOCK NUT
MP 1299	LOCK WASHER
MP 1295	OILITE BUSH
CC 383	ANGULAR CONTACT BEARING
CC 384	ANGULAR CONTACT BEARING

PLATE 1

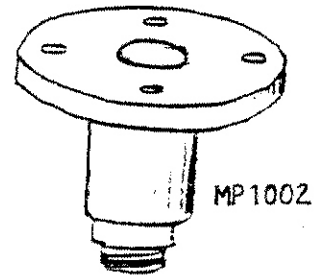
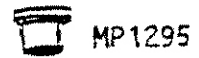
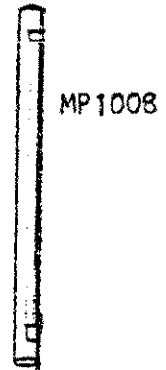
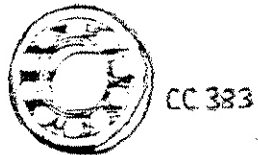
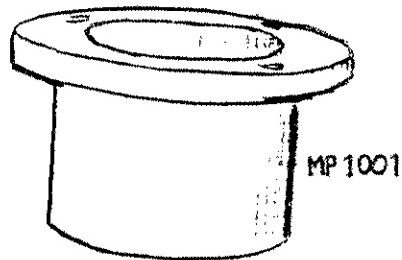
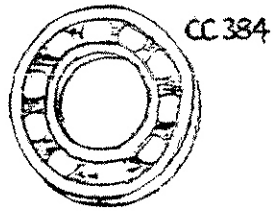

PLATE 2  
HORN ASSEMBLY

<u>PART NUMBER</u>	<u>DESCRIPTION</u>
MP 201	HORN
MP 203	WHIRL DRIVE GEAR (LOWER)
MP 204	BACK SHAFT
MP 206	LONG ROLLER
MP 205	WHIRL PINION DRIVE
MP 207	ROLLER SHAFT
MP 208	ROLLER SHAFT
MP 209	HORN TIP
MP 211	UNIVERSAL JOINT
MP 212	HORN TREAD ROLLER
MP 1236	ROLLER SHAFT
MP 1237	PINION
MP 1238	WHIRL
MP 1239	HORN ELBOW COVER
MP 1372	HORN CAP
MP 213	THREAD RETAINING CLIP
MP 1301	HORN COVER
MP 1303	HORN COVER HINGE

PLATE 2

WHIRL  
MP1238



CAP  
MP1372



MP213



PINION  
MP1237



TIP  
MP209



MP205



MP1239



MP211



MP201

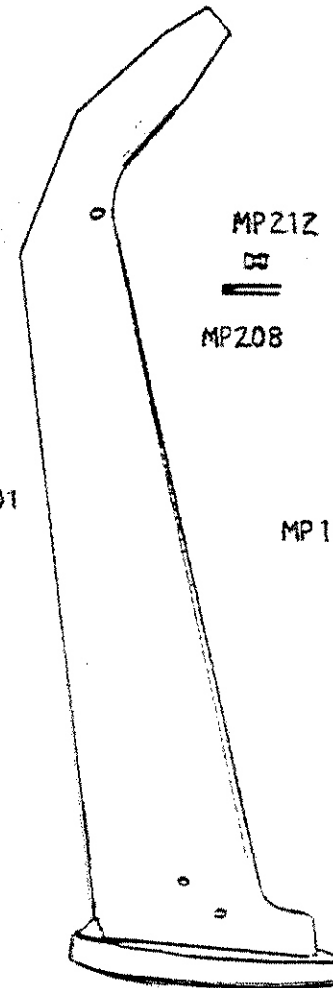

MP212

MP208

MP1301

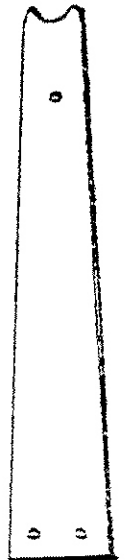

MP204



MP212



MP1236

MP206

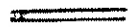

MP207

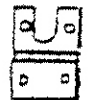
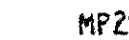

MP1303

MP203



PLATE 3  
TAKE DOWN ASSEMBLY FRAME

<u>PART NUMBER</u>	<u>DESCRIPTION</u>
MP 400	TOP PLATE
MP 401	FRONT GEAR SUPPORT PLATE
MP 402	REAR BEVEL GEAR PLATE
MP 1285	TENSION DISC
MP 1281	THREAD TENSION SHAFT
MP 1283	TENSION ADJUSTER NUT
MP 1280	TENSION DISC
MP 1284	TENSION DISC WASHER
MP 1282	TENSION DISC SHAFT
MP 1286	THREAD ROLL STUD
MP 1287	THREAD ROLL
MP 1288	THREAD ROLL COVER
MP 1306	THREAD LUB. ROLL BRACKET
MP 1305	THREAD LUB. TANK BRACKET
MP 1308	THREAD LUB. STUD
MP 1309	THREAD LUB. CAGE STUD SPACER
MP 1310A	THREAD LUB. TANK (NOT SHOWN)
MP 1352	TENSION PLATE SPRING
MP 1341	DISC COLLAR
MP 1342	THREAD STUD SPACER
MPSA 1230	THREAD SUPPORT BRACKET
MP 1333	CABLE GUIDE
MP 1417	ROLLER PIN





PLATE 3A  
TAKE DOWN ASSEMBLY FRAME

<u>PART NUMBER</u>	<u>DESCRIPTION</u>
MP 400	TOP PLATE
MP 401	FRONT GEAR SUPPORT PLATE
MP 402	REAR BEVEL GEAR PLATE
MP 1285	TENSION DISC
MP 1281	THREAD TENSION SHAFT
MP 1286	THREAD ROLL STUD
MP 1287	THREAD ROLL
MP 1288	THREAD ROLL COVER
MP 1306	THREAD LUB. ROLL BRACKET
MP 1305	THREAD LUB. TANK BRACKET
MP 1308	THREAD LUB. STUD
MP 1309	THREAD LUB. CAGE STUD SPACER
MP 1310A	THREAD LUB. TANK (NOT SHOWN)
MP 1352	TENSION PLATE SPRING
MP 1341	DISC COLLAR
MP 1342	THREAD STUD SPACER
MPSA 1230	THREAD SUPPORT BRACKET
MP 1333	CABLE GUIDE
MP 1417	ROLLER PIN

INTRODUCED WITH THE HORIZONTAL TYPE  
COP HOLDER DECEMBER 1989

PLATE 3A

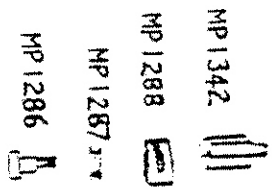
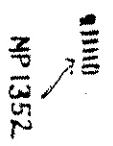
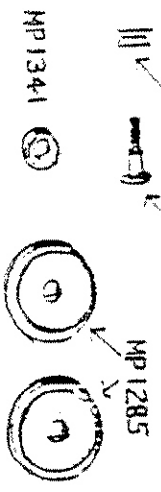
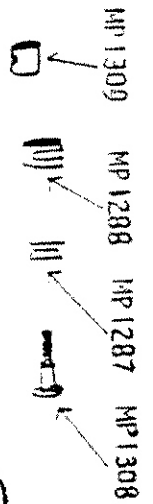
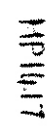
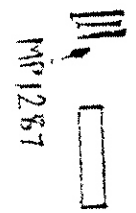
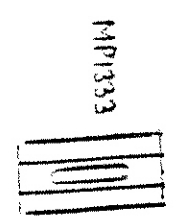
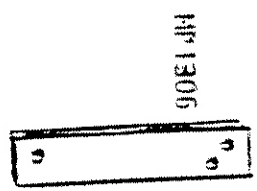
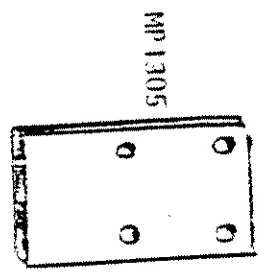
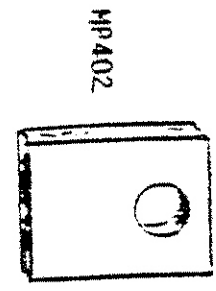
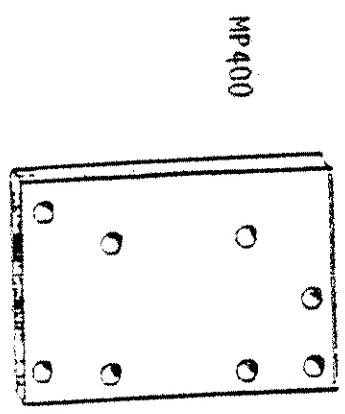
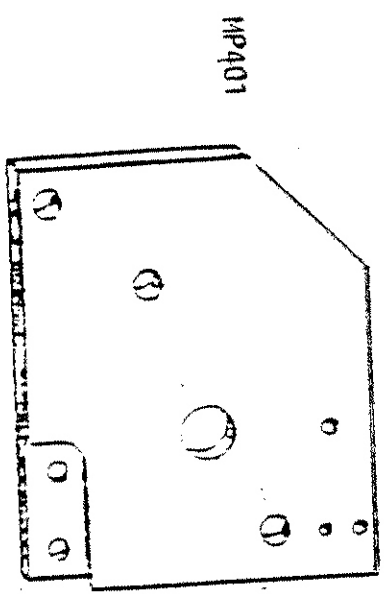
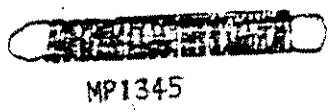

PLATE 4TAKE DOWN CAM AND LEVER

<u>PART NUMBER</u>	<u>DESCRIPTION</u>
MP 406	TAKE UP CAM GEAR
MP 417	CAM ROLLER
MP 420	ROLLER PIN
MP 1210	WASHER IN LEVER STUD
MP 1216	TAKE DOWN CAM
MP 1229	WASHER
MP 1292	OILITE BUSH FCM 15 x 25
MP 1286	THREAD ROLL STUD
MP 1287	THREAD ROLL
MP 1288	THREAD ROLL COVER
MP 1345	TAKE DOWN LEVER
MPSA 409	LEVER ASSEMBLY
MP 414	TAKE DOWN LEVER SHAFT
MP 1227	TAKE DOWN CAM SHAFT
MP 1411	WASHER



MP1345



MP1286



MP1287



MP1288

MP 414

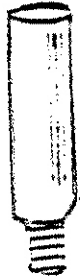

MPSA409

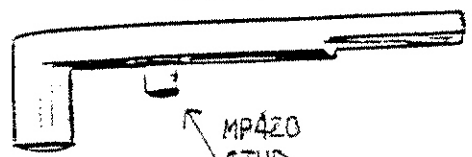

MP420  
STUD

MP1411



MP417



MP1210

MP1229

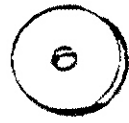

MP1292



MP1227



MP1216

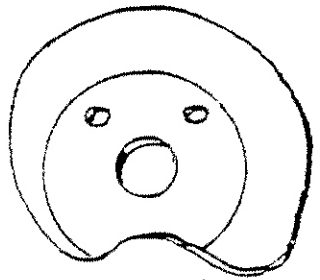

MP406

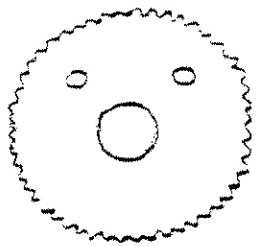

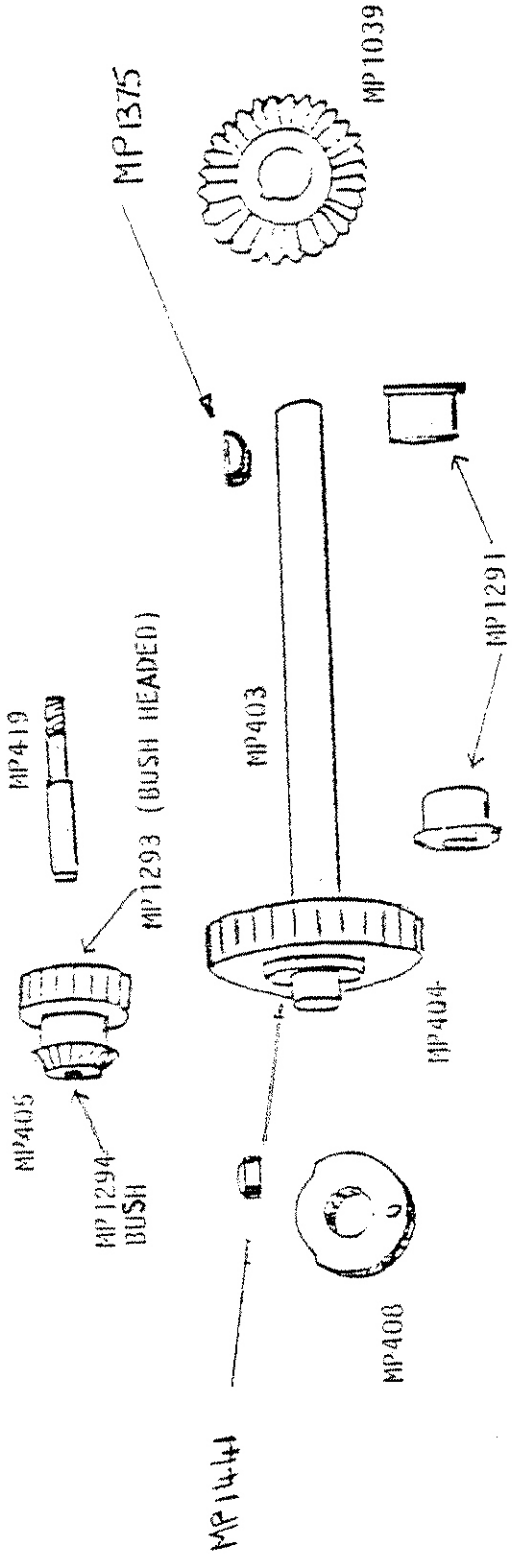
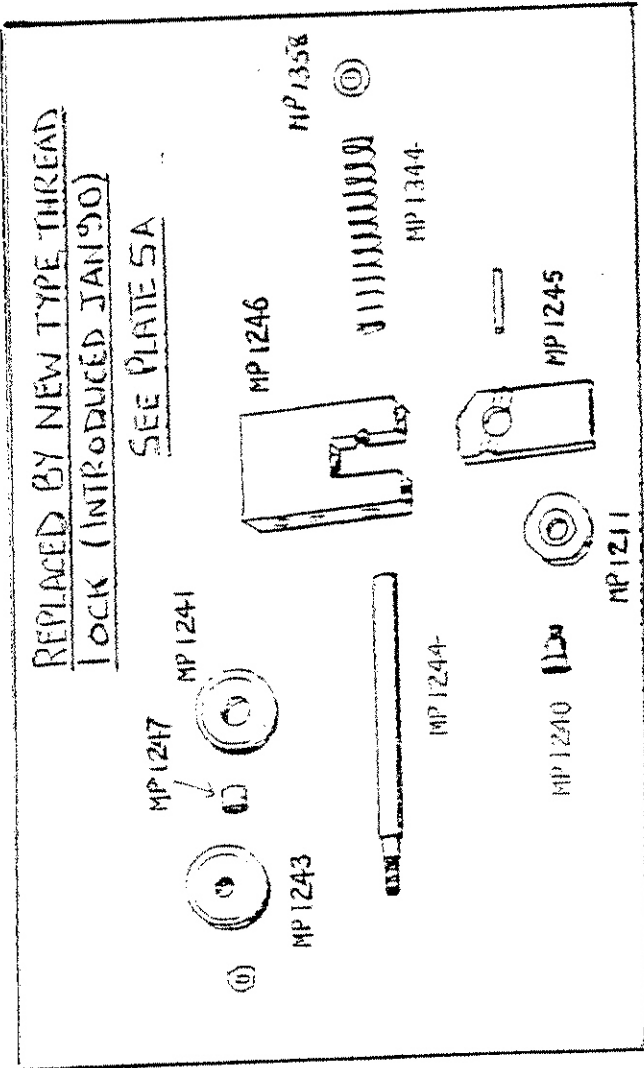

PLATE 5  
THREAD LOCK ASSEMBLY

<u>PART NUMBER</u>	<u>DESCRIPTION</u>
MP 403	GEAR SHAFT
MP 404	DRIVE GEAR
MP 405	HORN BASE DRIVE
MP 408	LOCK CAM
MP 419	BEVEL GEAR SHAFT
MP 1211 *	THREAD LOCK CAM ROLLER
MP 1244 *	THREAD LOCK SHAFT
MP 1243 *	THREAD LOCK FRONT DISC
MP 1242 *	THREAD LOCK ROLLER
MP 1241 *	THREAD LOCK CLAMP SPACER
MP 1240 *	LOCK ROLLER STUD
MP 1246 *	THREAD LOCK BLOCK
MP 1245 *	THREAD LOCK LEVER
MP 1291	OILITE BUSH FCM 17 x 18
MP 1293	OILITE BUSH FCM 12 x 16
MP 1294	OILITE BUSH CM 20 x 8
MP 1344 *	LOCK SPRING
MP 1039	BEVEL GEAR
MP 1441	6 x 6 x 16 KEY
MP 1375	WOODRUFF KEY
MP 1358 *	WASHER

PART NUMBERS MARKED \* REPLACED BY PARTS ON PLATE 5A  
 (INTRODUCED JANUARY 1990).

# THREAD LOCK (INTRODUCED JAN 90)

PLATE SA

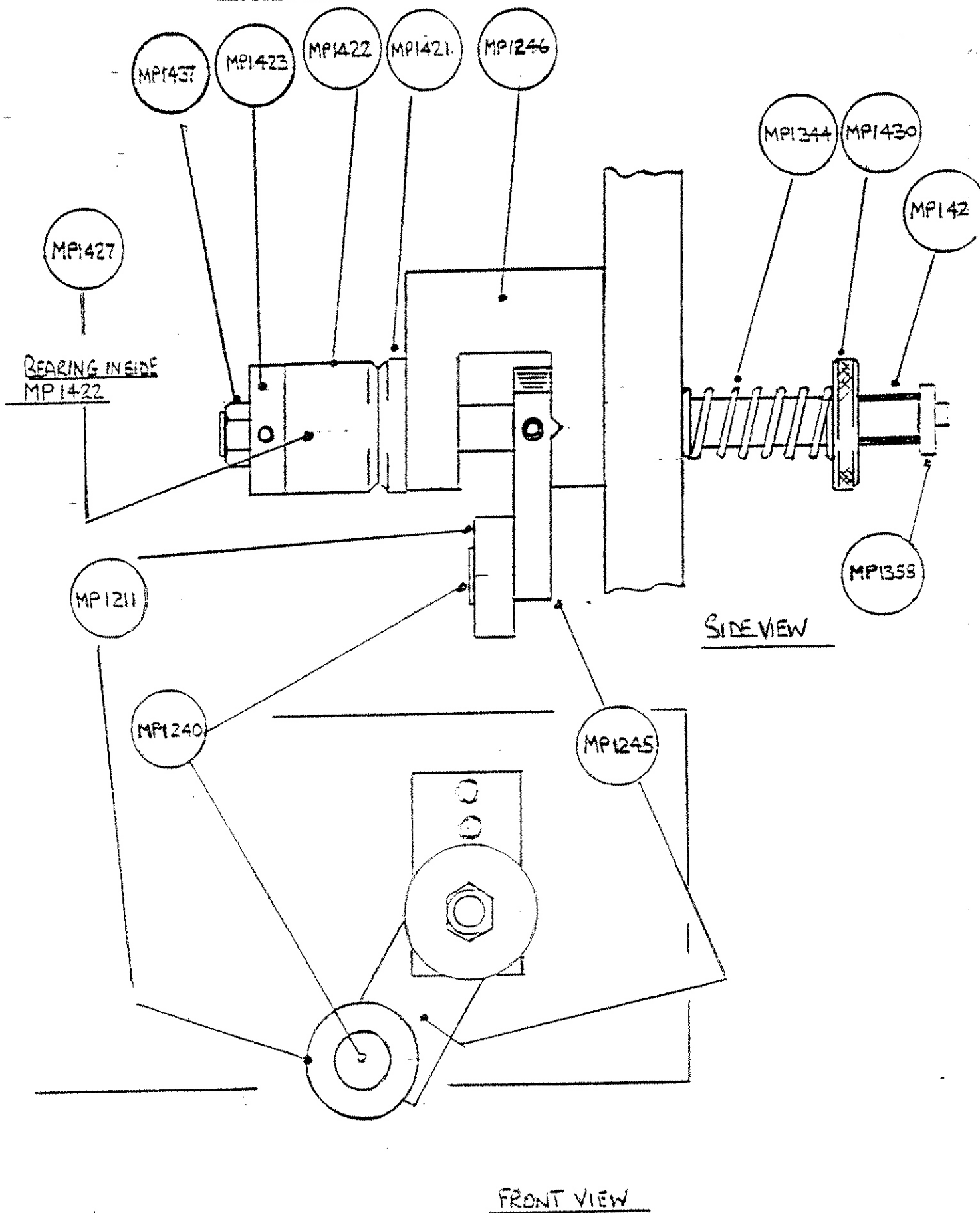

PLATE 5A  
THREAD LOCK (INTRODUCED JANUARY 1990)

<u>PART NUMBER</u>	<u>DESCRIPTION</u>
MP 1211	THREAD LOCK ROLLER
MP 1240	THREAD LOCK ROLLER STUD
MP 1245	THREAD LOCK LEVER
MP 1246	THREAD LOCK BLOCK
MP 1344	LOCK SPRING
MP 1421	BACK DISC
MP 1422	FRONT DISC
MP 1423	LOCKING DISC
MP 1424	LOCK START
MP 1427	BEARING
MP 1430	ADJUSTING
MP 1437	NUTS
MP 1358	WASHER



PLATE 6  
BACK SHAFT SECTION

<u>PART NUMBER</u>	<u>DESCRIPTION</u>
MP 1035	BACK SHAFT WASHER
MP 1037	BACK SHAFT
MP 1039	BEVEL GEAR
MP 1022	HANDWHEEL LOWER GEAR
MP 1201	HANDWHEEL BEVEL GEAR
MP 1025	HANDWHEEL SHAFT
MP 1027	HANDWHEEL PULLEY
MP 1020	HANDWHEEL BEARING HOUSING
MP 1040	BACK SHAFT BEARING HOUSING
MP 1291	OILITE BUSH FCM 17 x 18
MP 1296	OILITE BUSH FCM 16 x 16
MP 137C	PLASTIC HANDWHEEL RIM
MP 1375	WOODRUFF KEY

PLATE 6

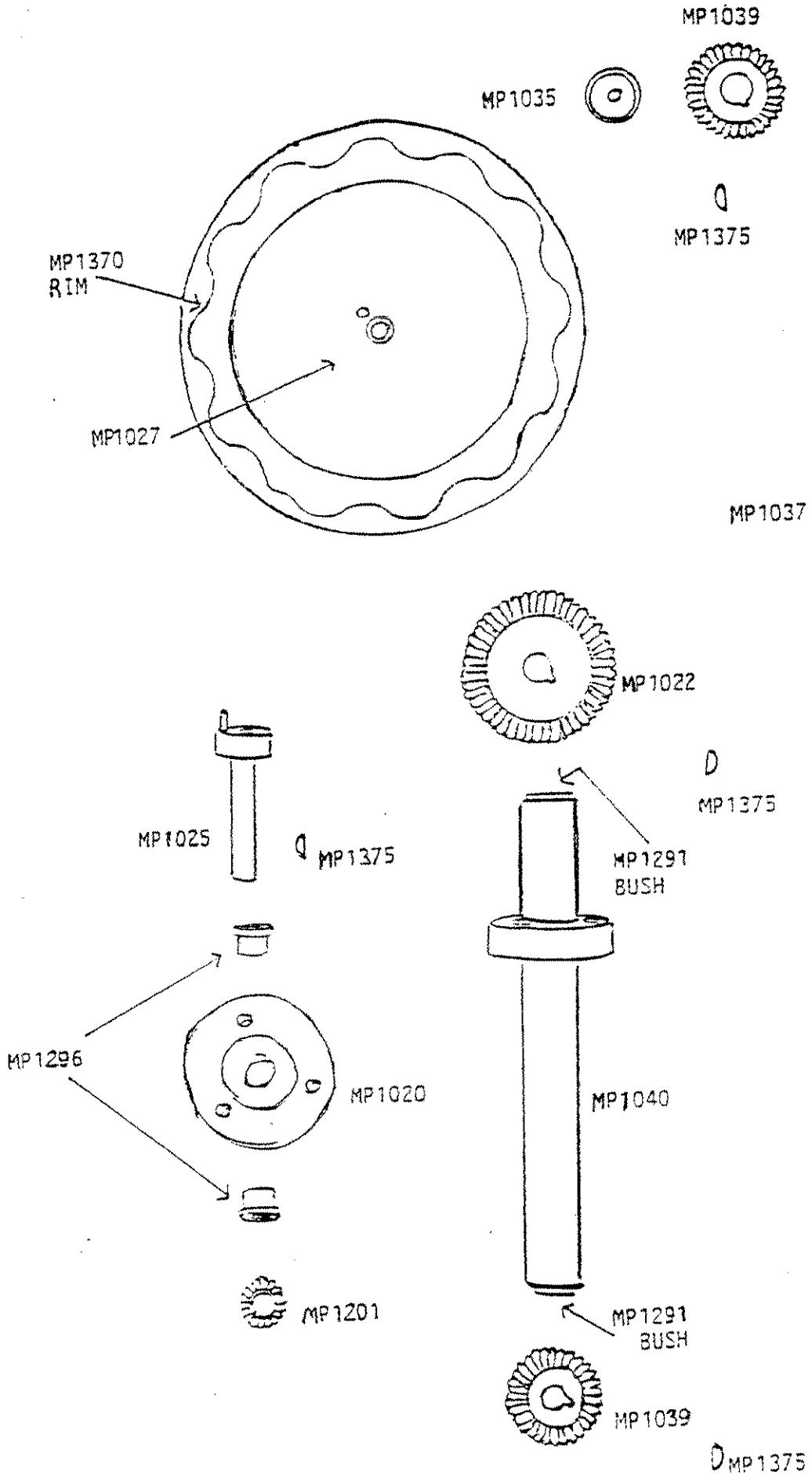

PLATE 7HEAD FRAME ASSEMBLY

<u>PART NUMBER</u>	<u>DESCRIPTION</u>
MP 1050	HEAD SHAFT BEARING HOUSING
MP 1126	HEAD TOP PLATE
MP 1127	HEAD BOTTOM PLATE
MP 1132	L H SIDE PLATE
MP 1133	R H SIDE PLATE
MP 1051	HEAD BACK PLATE
MP 1291	OILITE BUSH FCM 17 x 18
MP 1350	FRONT PRESSER FOOT PLATE
MP 1351	REAR PRESSER FOOT PLATE
MP 1283	ADJUSTER SCREW LOCK NUT
MPSA 1205	ADJUSTER SCREW ASSEMBLY
MP 1331	COLLAR

PLATE 7

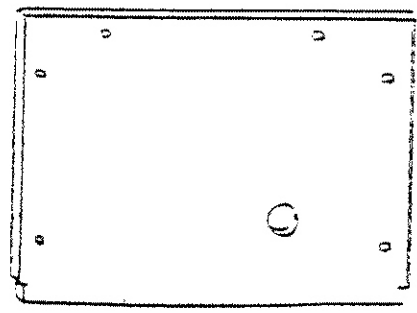
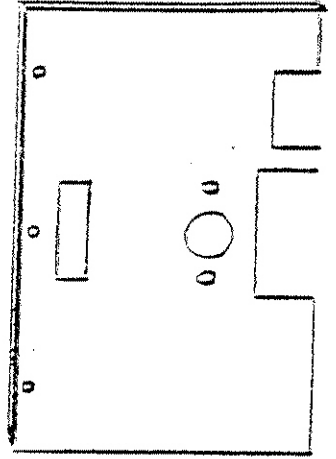
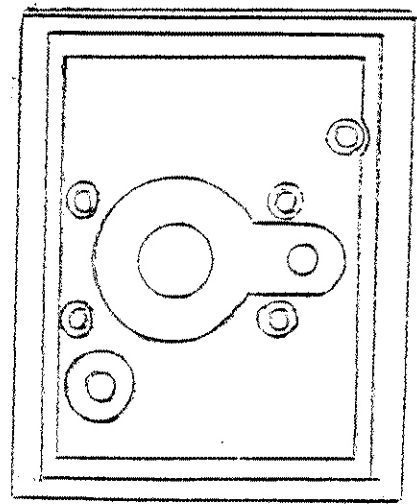
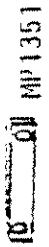
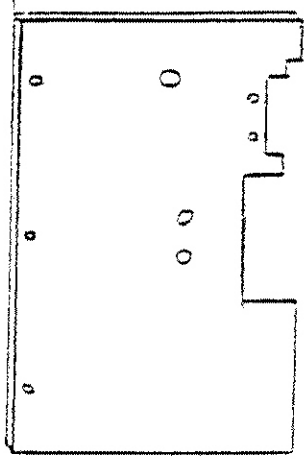
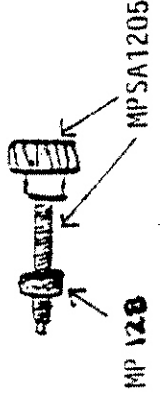
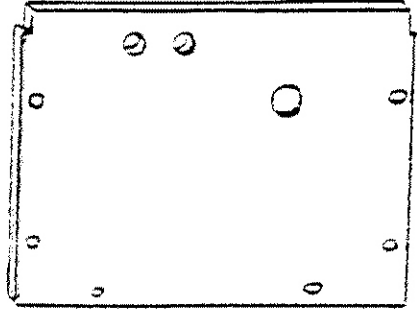
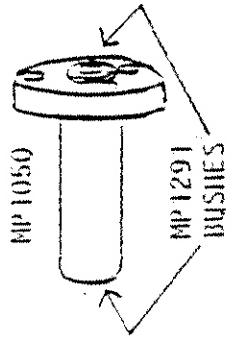

PLATE 8TOP SHAFT AND GENEVA CAM ASSEMBLY

<u>PART NUMBER</u>	<u>DESCRIPTION</u>
MP 1150A	GENEVA STAR SHAFT
MP 1147A	IDLER SHAFT STUD
MP 1148	BEVEL GEAR SHUTTLE DRIVE
MP 1152	SHUTTLE INTERMEDIATE GEAR
MP 1145A	GENEVA CAM AND GEAR
MP 1291	OILITE BUSH FMC 17 x 18
MP 1053	HEAD SHAFT
MP 1065	NEEDLE BAR DRIVER
MP 1063	FRONT SHAFT SUPPORT HOUSING
MP 1146A	GENEVA DRIVE DISC
MP 1200	DOUBLE CAM
MP 1213A	GENEVA CAM STUD
MP 1214	GENEVA CAM ROLLER
MP 1311	NEEDLE CAM ROLL STUD
MP 1039	BEVEL GEAR
MP 1359	SPRING
MP 1411	BEVEL WASHER
MP 1413	BUSH
MP 1438	5 x 5 x 35 KEY
MP 1439	5 x 5 x 10 KEY

IMPORTANT NOTE

PART NO'S. MP 1150A  
 MP 1147A  
 MP 1145A  
 MP 1413

Introduced on machine serial No. 88704.

All machines after this serial number will contain these part numbers.

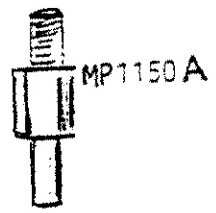

MP1150 A

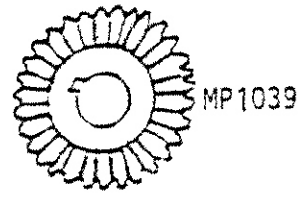

MP1039

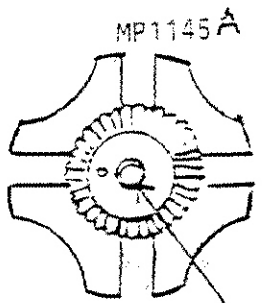

MP1145 A

MP1213A  
STUD



MP1214  
ROLLER

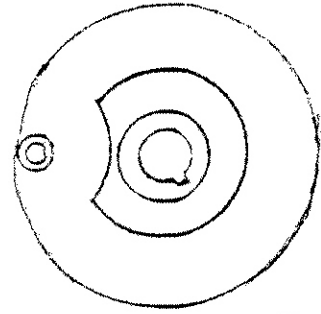

MP1146A



MP1440

MP1438

MP1053

MP1439

MP1411



MP1413 BUSH

MP1200

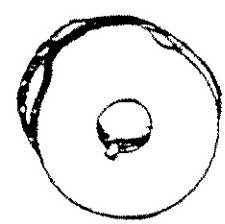

MP1148  
BEVEL GEAR

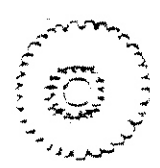

MP1442  
KEY

MP1152

~~MP1359~~ MP1359

MP1291

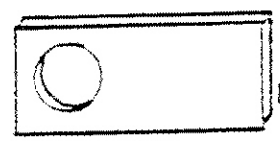

MP1063

MP1147A



MP1311

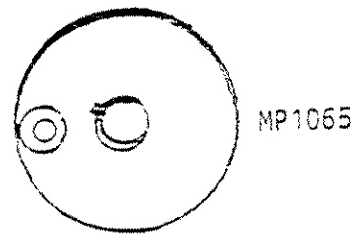

MP1065

PLATE 9NEEDLE BAR ASSEMBLY

<u>PART NUMBER</u>	<u>DESCRIPTION</u>
MP 1202	NEEDLE BAR
MP 1232	NEEDLE BAR CAM HOLDING BLOCK
MP 1233	NEEDLE BAR CAM
MP 1234	NEEDLE CLAMP
MP 1235	NEEDLE STOP PIN
MP 1371,6	NEEDLE ART 4001 SIZE 6
MP 1312	NEEDLE CAM ROLL
MP 1128	NEEDLE BAR BEARING BLOCK
MP 1360	OILITE BUSH CM 31 x 20

MP1360



MP1312



MP1128



MP1202



MP1233

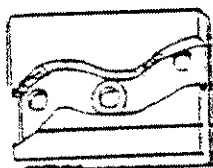

MP1232

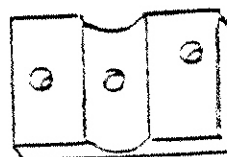

MP1234



MP1235



MP1128



MP1371,6



MP1360



PLATE 10PRESSER FOOT AND PAWL BLOCK ASSEMBLY

<u>PART NUMBER</u>	<u>DESCRIPTION</u>
MP 1250	PRESSER FOOT BAR CARRIER
MP 1251	PRESSER FOOT BAR
MP 1253	PRESSER FOOT SLIDE BAR
MP 1297	GLACIER BUSH DX 16 x 18 x LG
MP 1316	PAWL CAM PIECE
MP 1315	PRESSER FOOT SPRING PIN
MP 1318	SPRING ANCHOR
MP 1319	PRESSER FOOT SHAFT SPRING
MP 1320	PAWL RELEASE CAM
MP 1321	PRESSER FOOT PAWL BLOCK
MP 1322	PAWL
MP 1323	PRESSER FOOT PRESSURE SPRING
MP 1408	SINGLE POINT PRESSER FOOT
MP 1409	DOUBLE POINT PRESSER FOOT
MP 1254	PAWL HOUSING BLOCK
MP 1255	PAWL CAM RELEASE PLATE
MP 1257	PRESSER FOOT PAWL
MP 1324	PAWL SETTING PIECE
MP 1325	PAWL SPRING
MP 1343	PAWL STUD
MP 1374	PIVOT PIN
MP 1331	COLLAR



MP1318



MP1315

4 X MP1297  
BUSHES

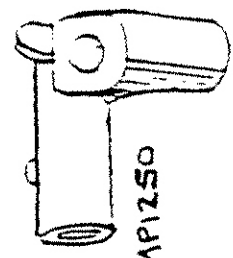

MP1250

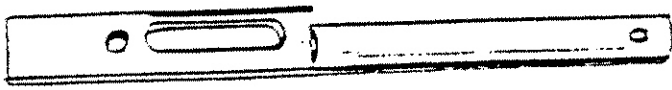

MP1251



MP1320



MP1319

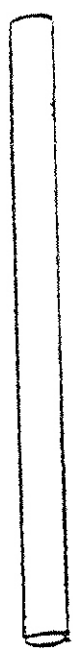

MP1253



MP1331

MP1321



MP1322

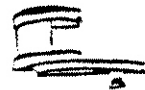

MP1376

MP1317

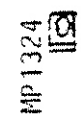

MP1324



MP1316



MP1255



MP1254



MP1325

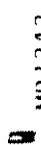

MP1343



MP1257

MP1323



MP1324



MP1343



MP1325



MP1408

SINGLE POINT



MP1409

DOUBLE POINT

PLATE 11PRESSER FOOT LIFT AND FEED LEVER ASSEMBLY

<u>PART NUMBER</u>	<u>DESCRIPTION</u>
MP 1206	PRESSER FOOT LIFT BAR
MP 1260	PRESSER FOOT FEED LINK
MP 1261	FEED LEVER LINK SPACER
MP 1262	FEED AND LIFT CAM ROLLER
MP 1263	LEVER ROLLER STUD
MP 1264	FEED LINK PIVOT STUD
MP 1265	PRESSER FOOT LIFT LEVER
MP 1268	LIFT LEVER FORK STUD
MP 1269	LIFT LEVER LINK WASHER
MP 1289	LEVER SPRING BRACKET
MP 1313	SPACER
MP 1290	RISE AND FALL LEVER SPRING
MP 1363	PRESSER FOOT RETURN SPRING
MPSA 1259	PRESSER FOOT FEED LEVER
MP 1203	LEVER STUD
MP 1271	CABLE LIFT PILLAR
MP 1272	LIFT PILLAR HOUSING
MP 1410	WASHER

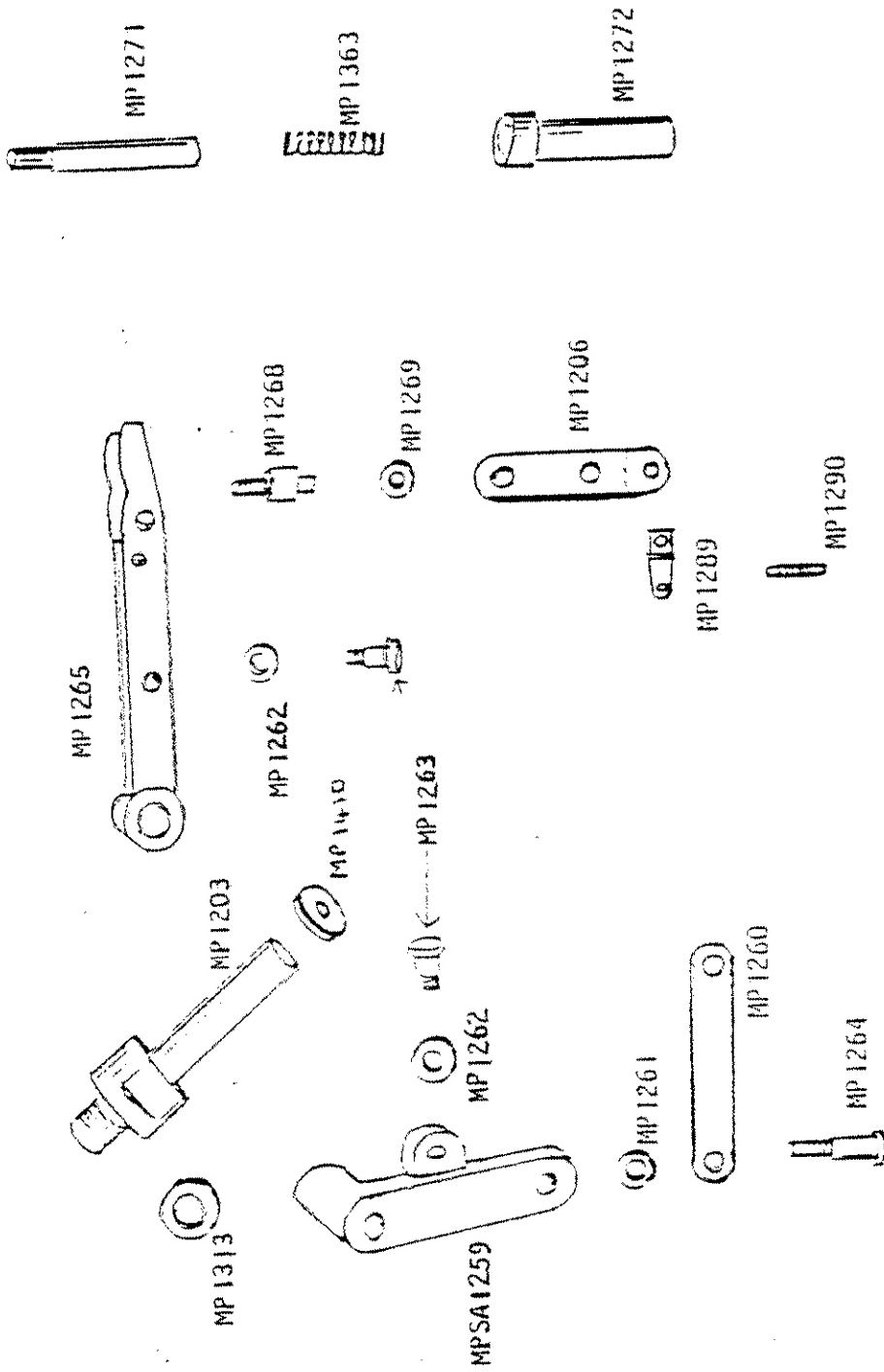

PLATE 12SHUTTLE HOUSING ASSEMBLY

<u>PART NUMBER</u>	<u>DESCRIPTION</u>
MP 1112	WOODRUFF KEY 1/8 x 1/2
MP 1204	SHUTTLE DRIVER WASHER
MP 1151	SHUTTLE DRIVE GEAR
MP 1215	SHUTTLE POINT BLADE
MP 1217	SHUTTLE HOLDER
MP 1218	SHUTTLE RING
MP 1219	SHUTTLE
MP 1220	BOBBIN CASE
MPSA 1224	BOBBIN CASE SLEEVE ASSEMBLY
MP 1222	BOBBIN
MP 1343	PAWL STUD
MP 1364	BOBBIN CASE SHAFT SPRING
MP 1225	BOBBIN CASE SHAFT
MP 1373	PLASTIC KNOB
MPSA 1113	SHUTTLE DRIVER ASSEMBLY

PLATE 12

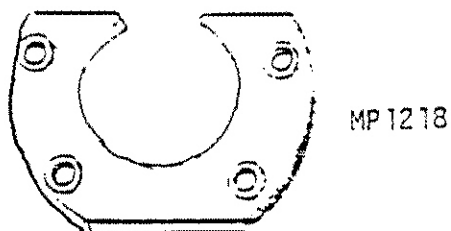
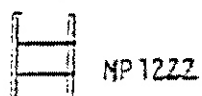
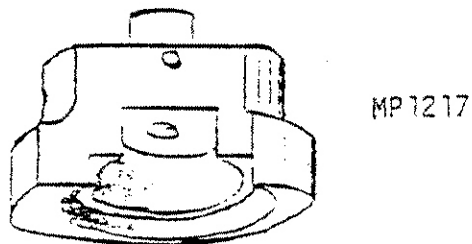
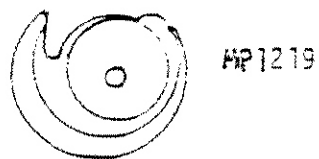
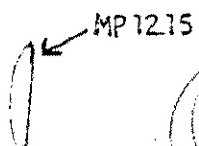
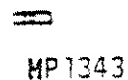
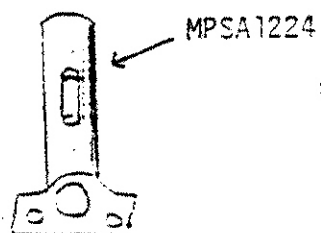
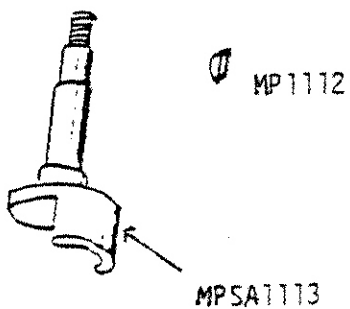
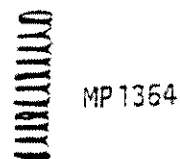
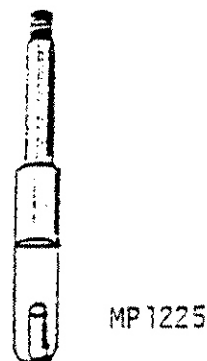
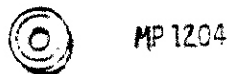
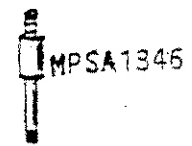
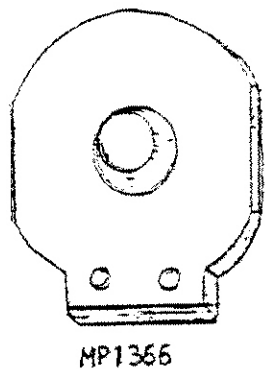
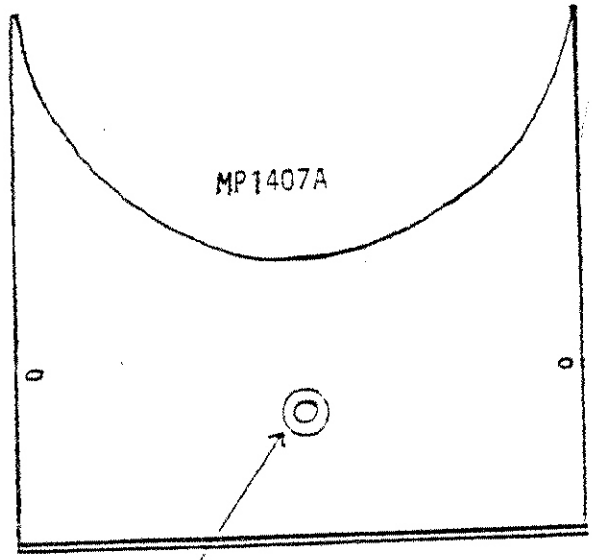
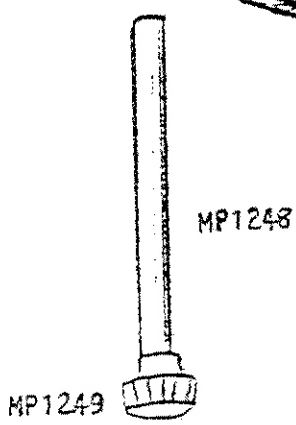
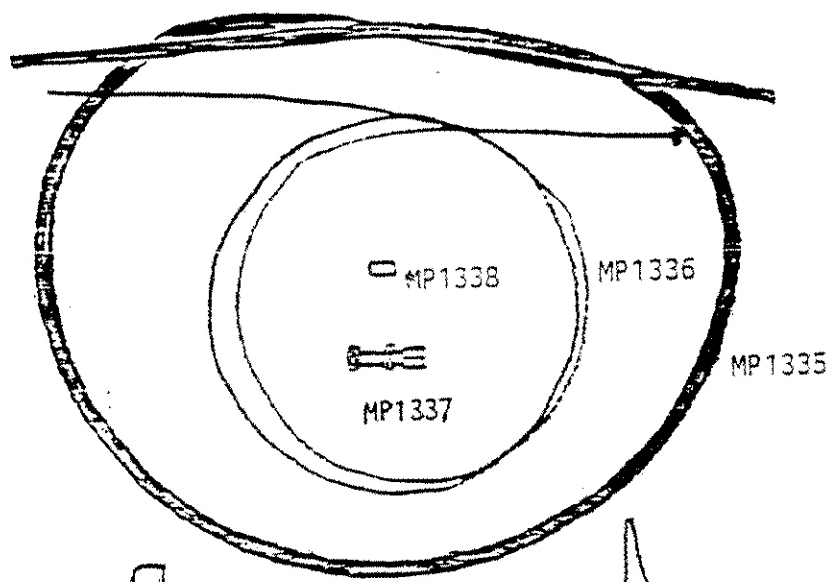

PLATE 13MISCELLANEOUS PARTS

<u>PART NUMBER</u>	<u>DESCRIPTION</u>
MP 1287	THREAD ROLL
MP 1335	CABLE OUTER
MP 1336	CABLE INNER
MP 1337	CABLE ADJUSTER 6MM
MP 1338	CABLE FERRULE SP3
MP 1407A	BELT GUARD COVER
MP 1366	SPOOL HOLDER (Replaced by horizontal type cop holder December 1989)
MP 1249	RENCOL KNOB
MP 1248	THREAD TENSION KNOB SHAFT
MPSA 1346	BOBBIN WINDER SHAFT
MP 1404	BOBBIN WINDER PULLEY
MP 1349	BUSH
MP 1347	BOBBIN DRIVE COLLAR
MP 1334	CABLE ADJUSTING BRACKET
ELE 594	CABLE CLIP



REPLACED BY HORIZONTAL TYPE  
CAP HOLDERS DECEMBER 1989



VERTICAL CLIP TYPE COP HOLDER

PLATE 13A

INTRODUCED JAN 1990

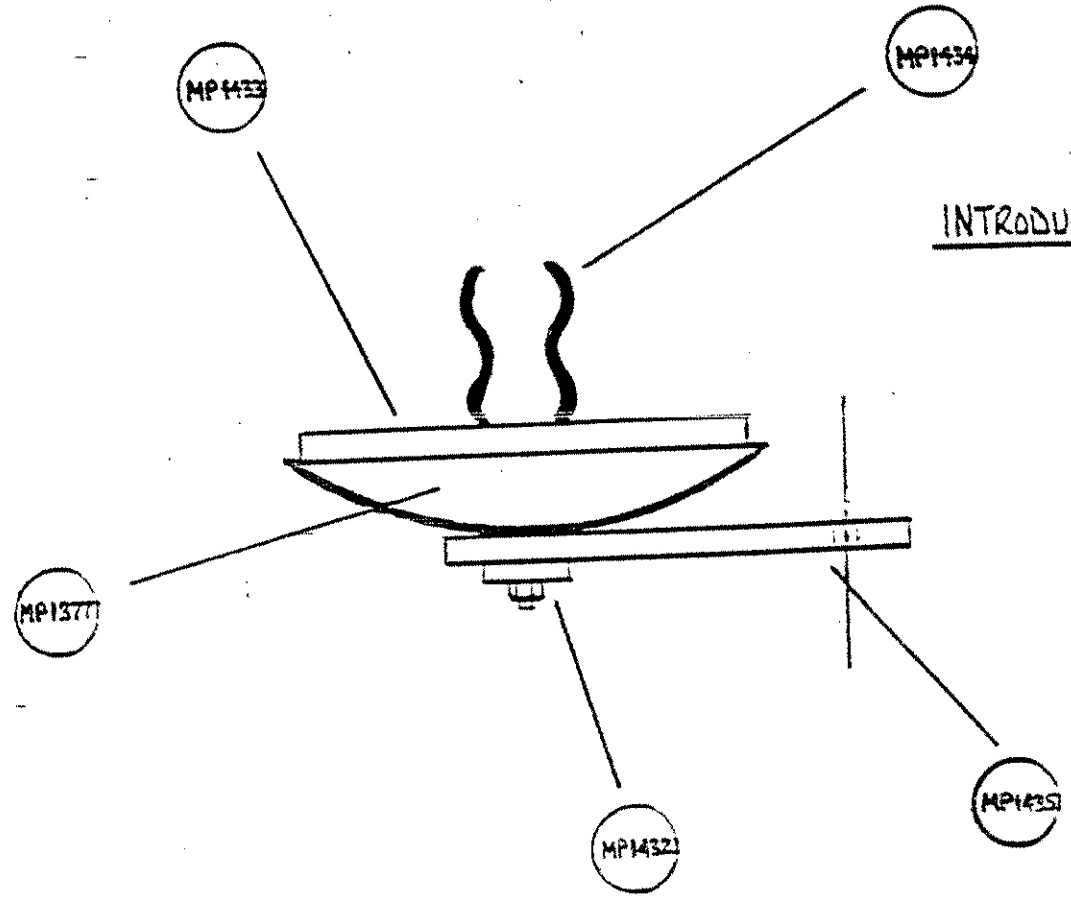

HORIZONTAL COP HOLDER FOR BOBBIN WINDER THREAD COP

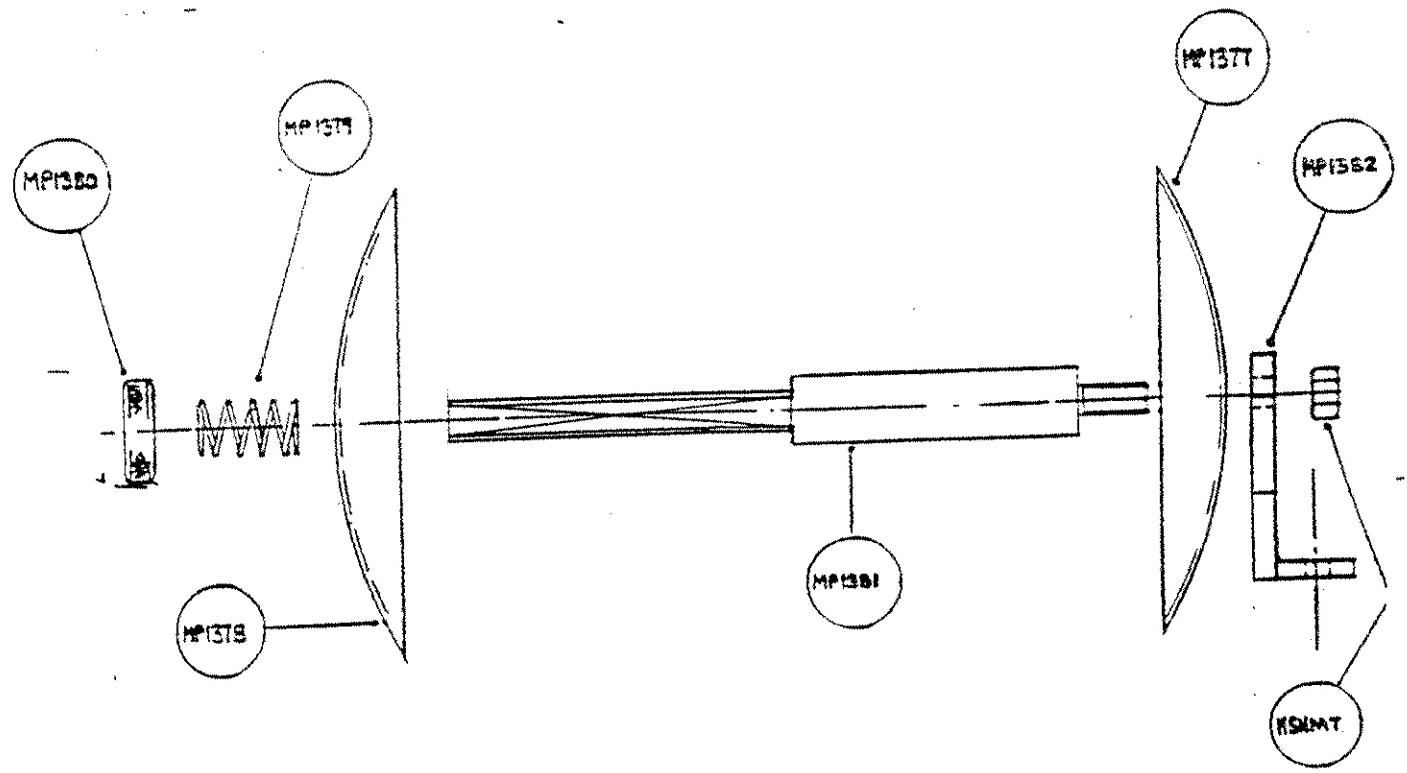

PLATE 13AVERTICAL CLIP TYPE COP HOLDER

<u>PART NUMBER</u>	<u>DESCRIPTION</u>
MP 1377	COP DISH
MP 1432	COP DISH BOSS
MP 1433	COP DISH PAD
MP 1434	COP DISH CLIP
MP 1435	MOUNTING PLATE FOR COP

HORIZONTAL TYPE COP HOLDER FOR BOBBIN WINDER

MP 1377	FIXED COP DISH
MP 1388	MOVEABLE COP DISH
MP 1379	TENSION SPRING
MP 1380	ADJUSTING NUT
MP 1381	COP DISH SHAFT
MP 1382	BRACKET FOR COP DISH
HSNM 7	NUT